



2022 | 11

**CS-Profi**



<b>ar:</b> السقف المشع الانزلاقي .....	24
<b>bg:</b> Покривало тип „щора“ .....	28
<b>cs:</b> Shrnovací střecha s posuvnou plachtou .....	32
<b>da:</b> Gardin trailerpresenning .....	36
<b>de:</b> Schiebegardin verdeck .....	40
<b>el:</b> Συρόμενη οροφή με κουρτίνα .....	44

<b>en:</b> Curtain Sider Roof .....	48
<b>es:</b> Cubierta de lona corrediza .....	52
<b>et:</b> Lükatav katusekardin .....	56
<b>fi:</b> Liukusuojapeitto .....	60
<b>fr:</b> Bâchage à rideau coulissant .....	64
<b>hu:</b> Elhúzzható függönyponyva .....	68
<b>it:</b> Copertura scorrevole .....	72
<b>ja:</b> スライド式カーテンルーフ .....	76
<b>lt:</b> Užsuolaidinis tentas .....	80
<b>lv:</b> Bidāms aizkara tipa pārsegs .....	84

<b>nl:</b> Schuifzeil .....	88
<b>pl:</b> Harmonijkowa plandeka przesuwna .....	92
<b>pt:</b> Cobertura deslizante em cortina .....	96
<b>ro:</b> Prelată culisantă .....	100
<b>ru:</b> Раздвижной тент .....	104
<b>sk:</b> Zhrnovacia strecha .....	108
<b>sl:</b> Zavesasta pomična streha .....	112

<b>sv:</b> Skjutpresenning .....	116
<b>th:</b> หลังกาผ้าผ่านแบบเลื่อน .....	120
<b>tr:</b> Kayar çatı .....	124
<b>zh:</b> 滑帘车篷 .....	128



1

1.

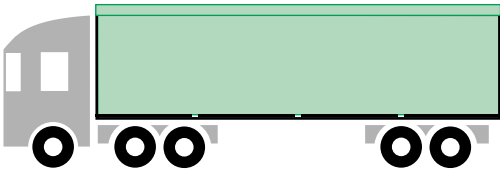

P

2.

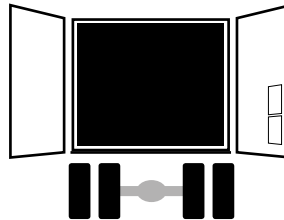

P

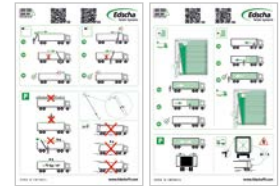

3.

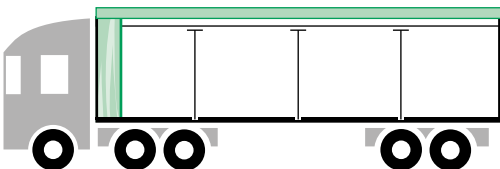

P

4.

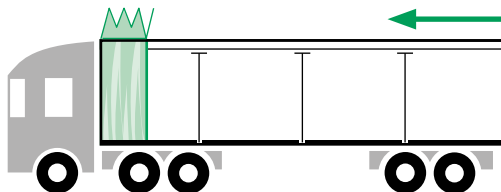

P

2

1.

P

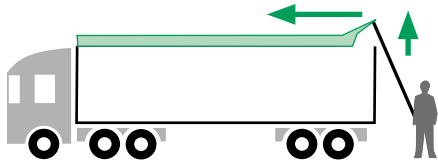

2.

P

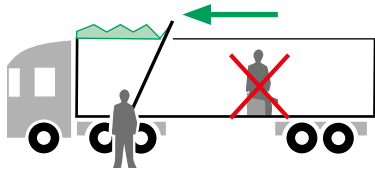

3.

P

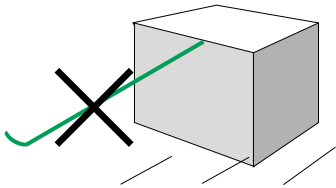
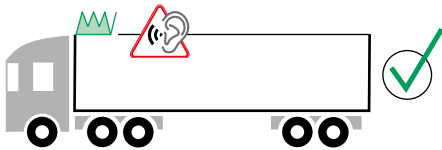

3

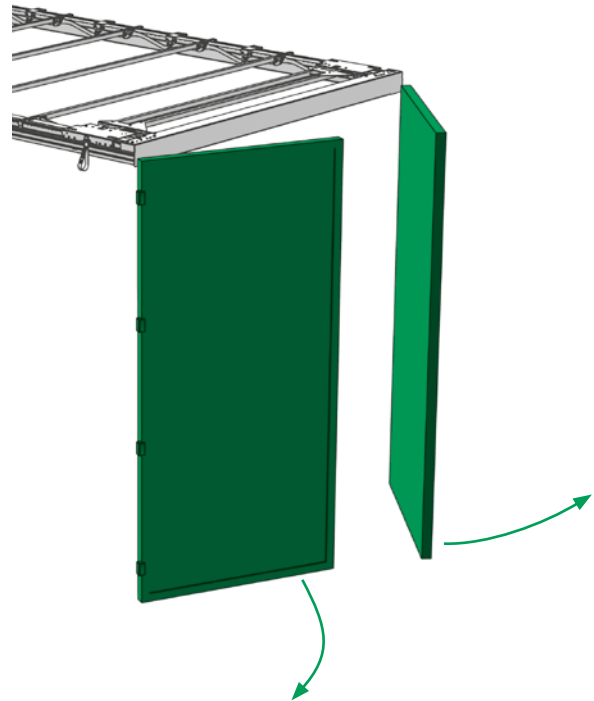



4

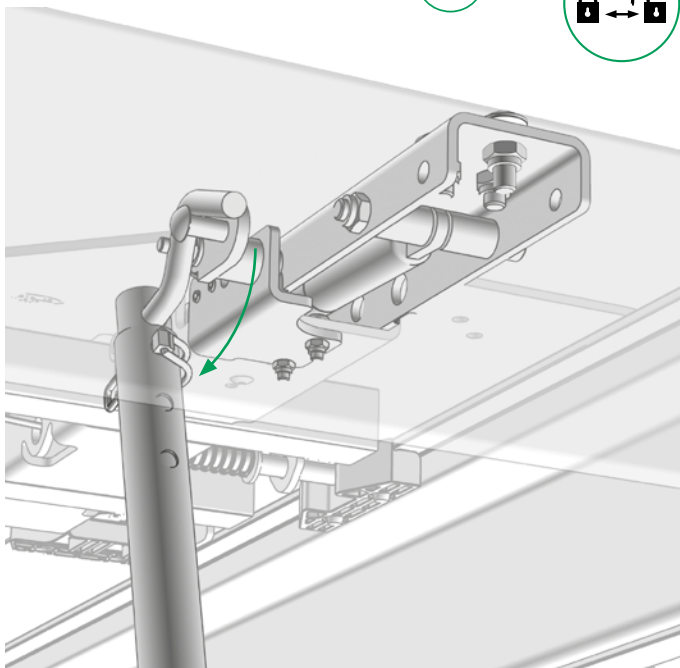

5



6

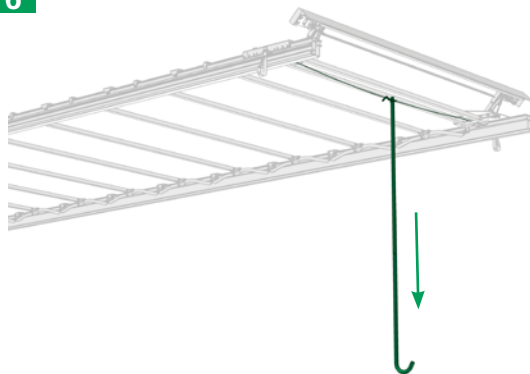





9

1.

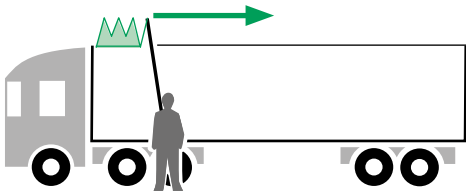

P

2.

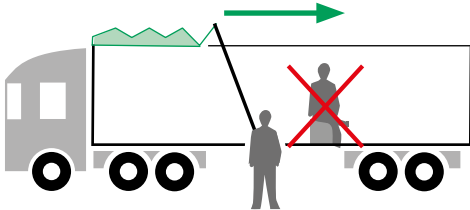

P

3.

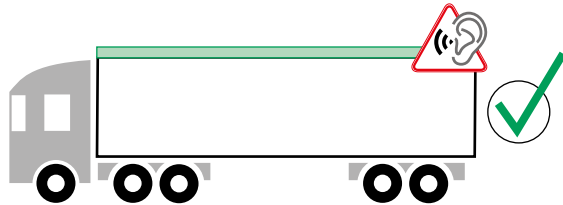

P

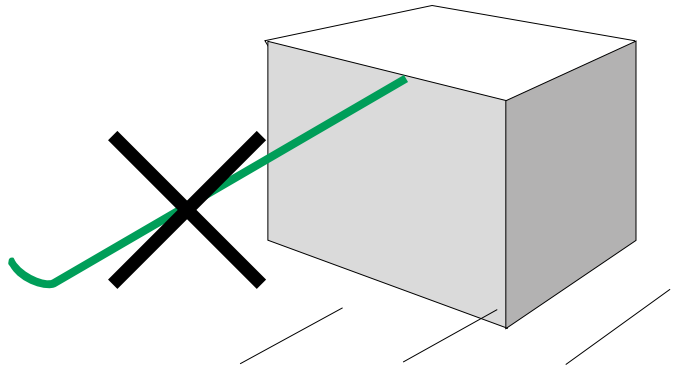

10

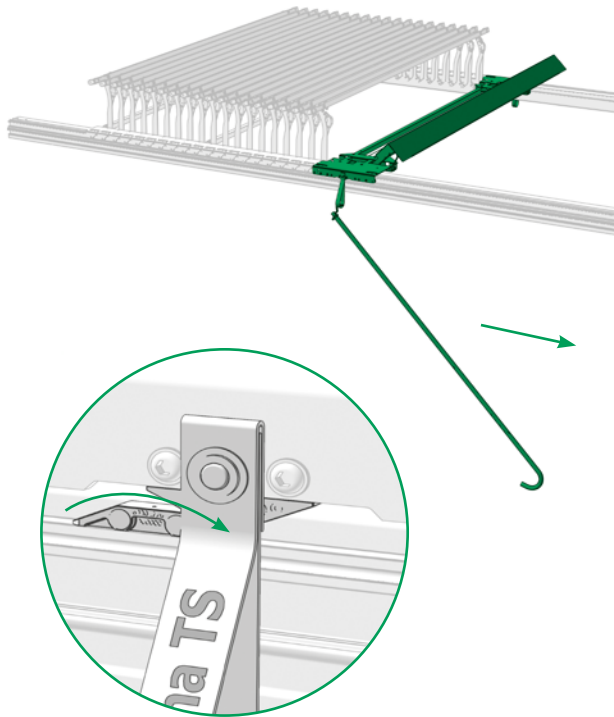

11



12





13

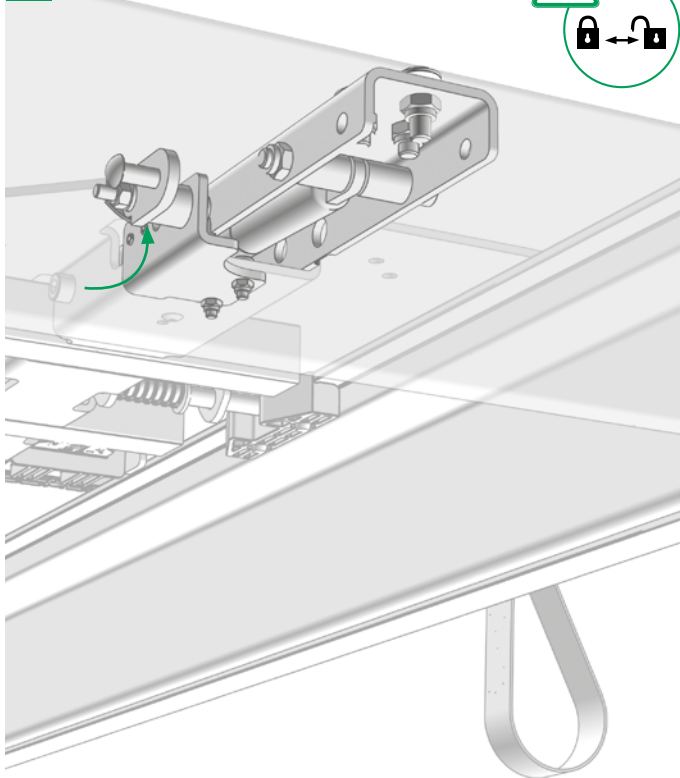

14





15

1.

P

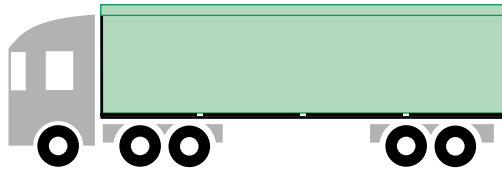

2.

P

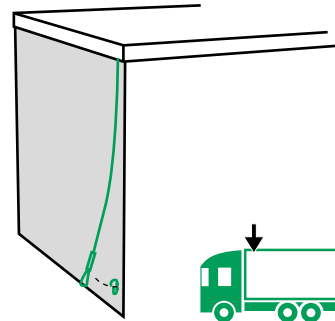

3.

P

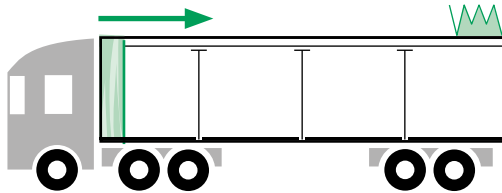

4.

P

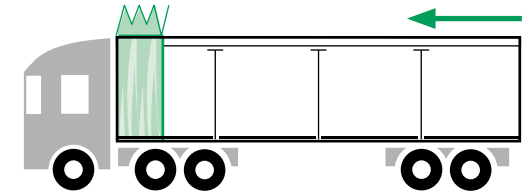

16

1.

P

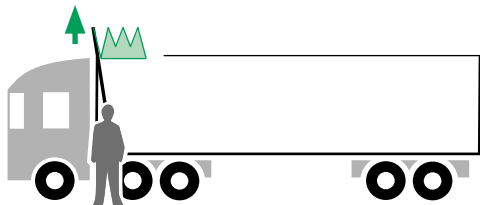

2.

P

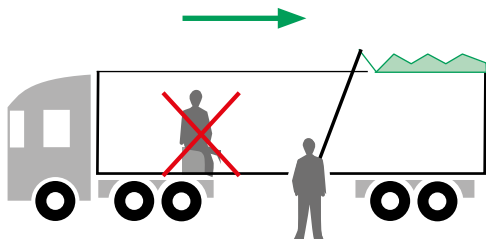

3.

P

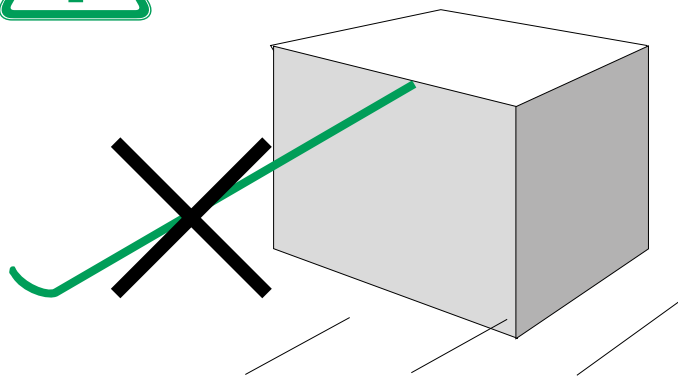
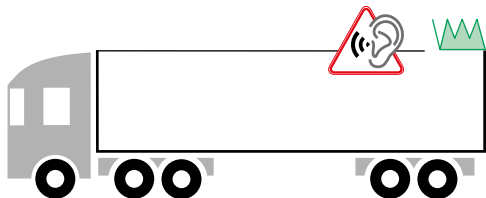

17

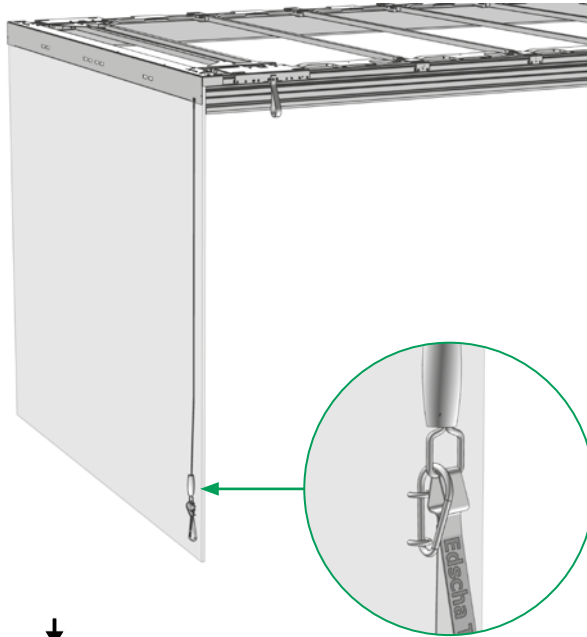

18

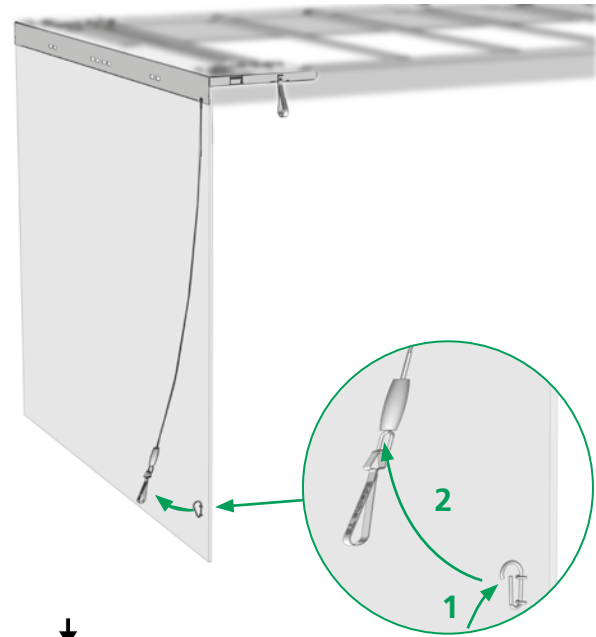



19

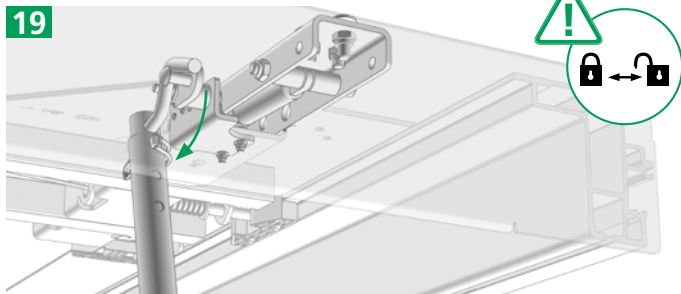

20



21

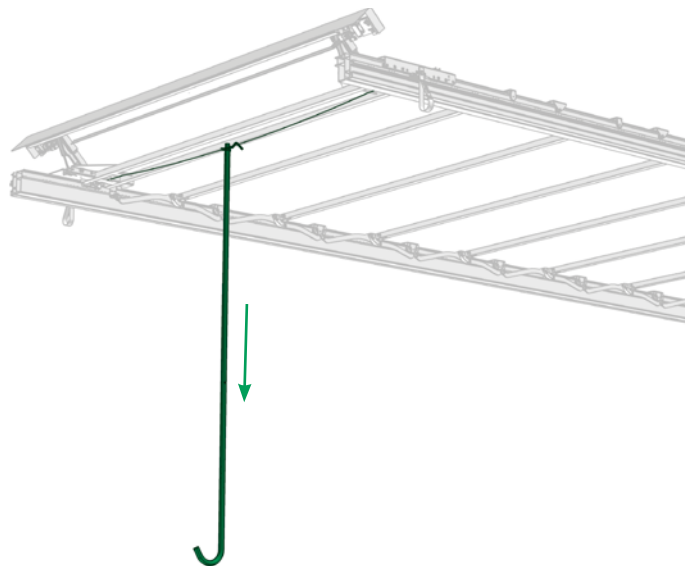

22

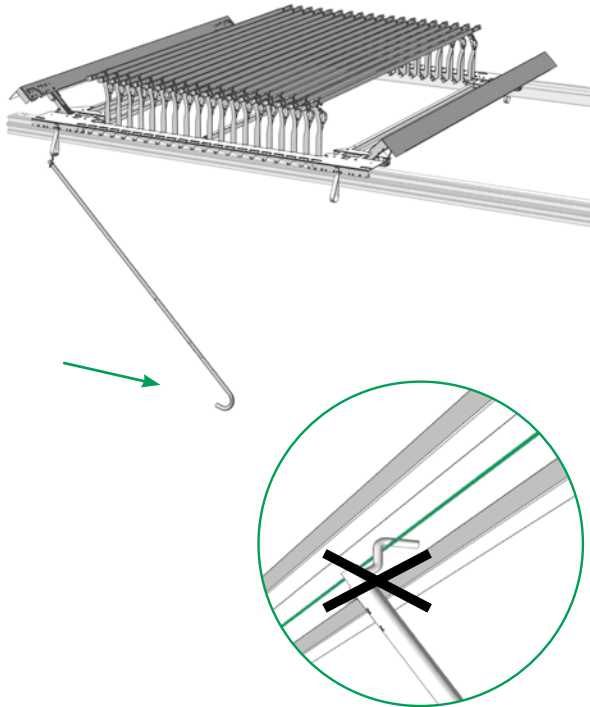

23

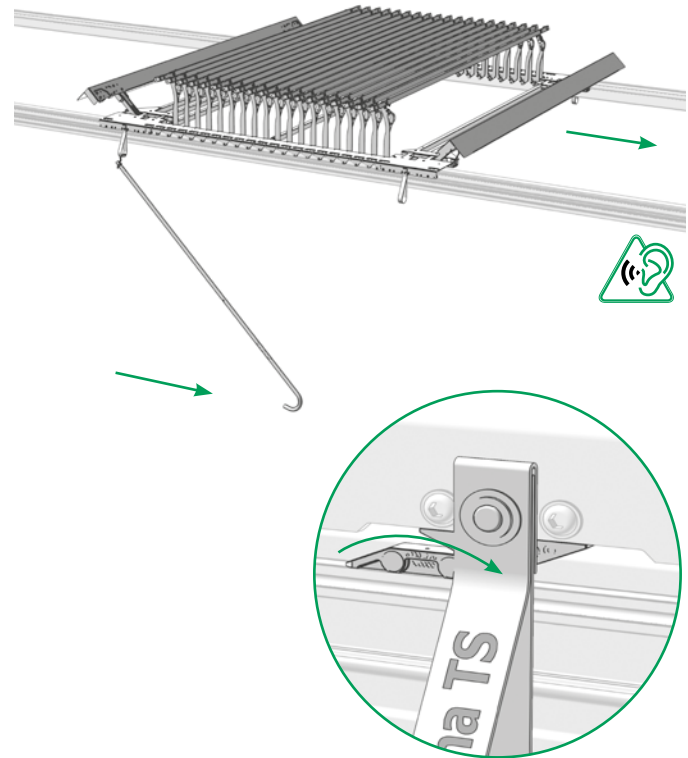

24

1.

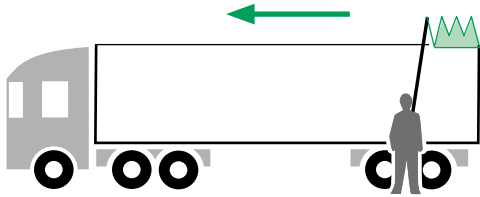

2.

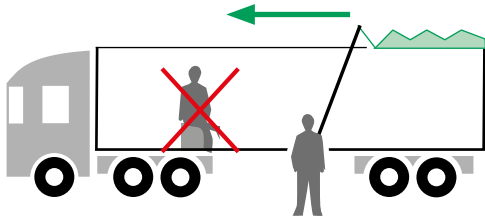

3.

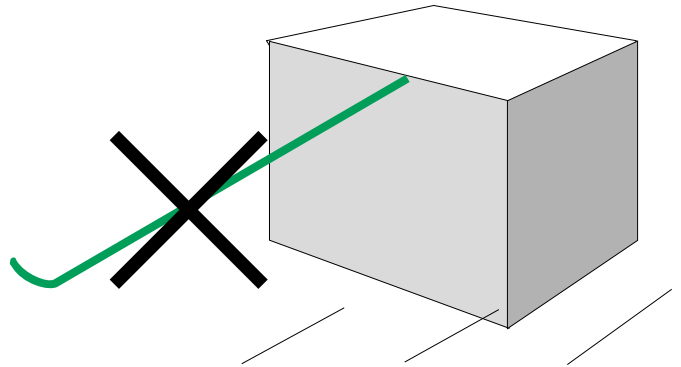
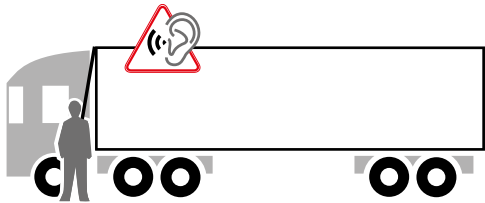

25

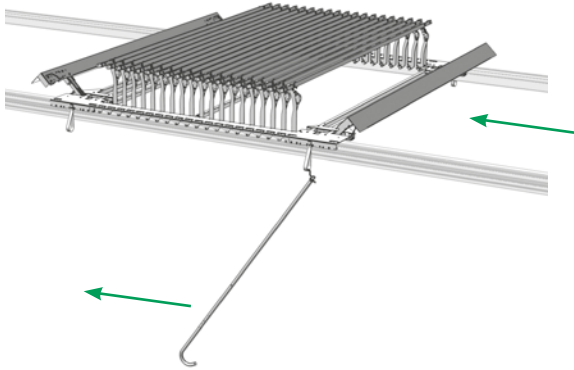

27



26

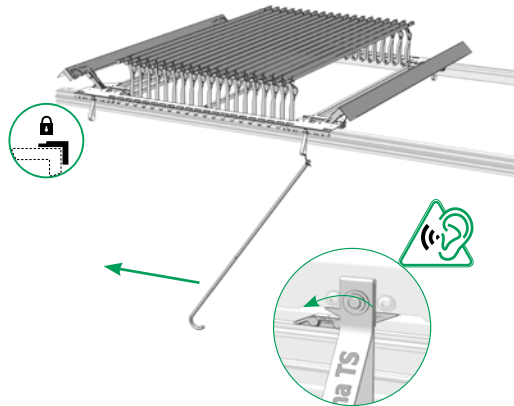

28

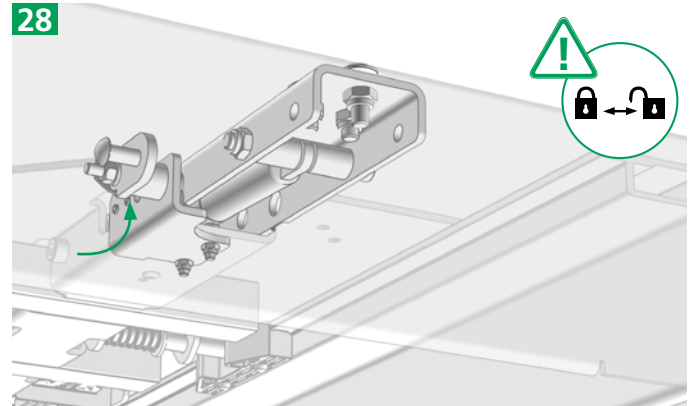



29

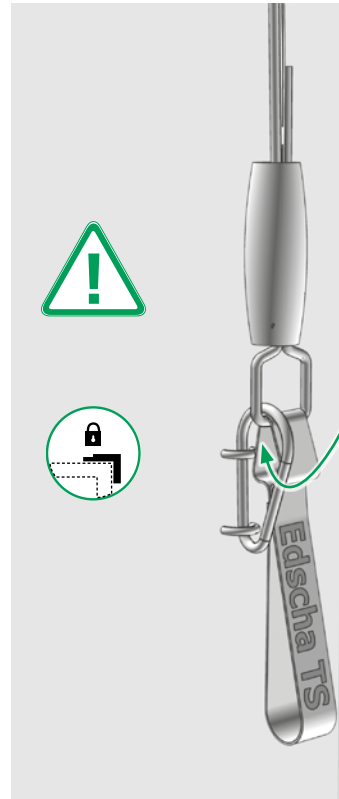
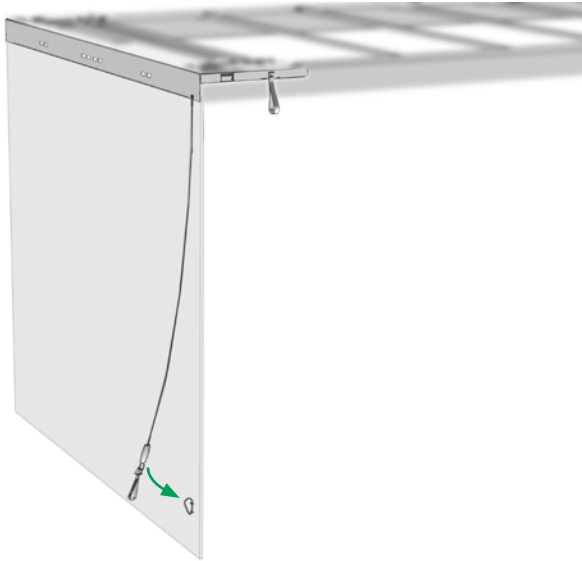



30

1.

P

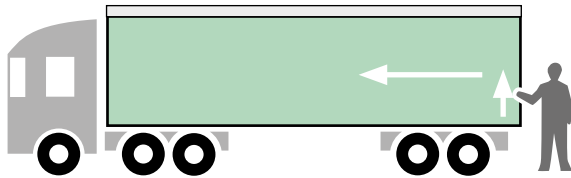

2.

P

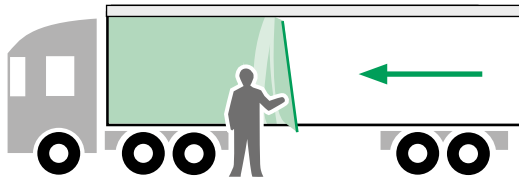

3.

P

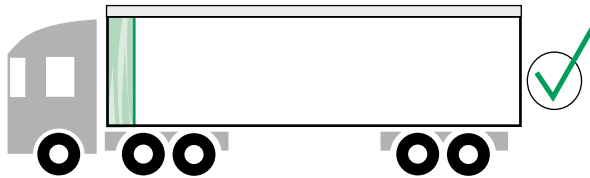

31

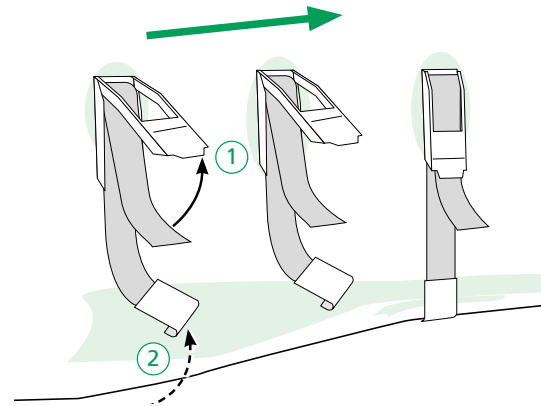

32

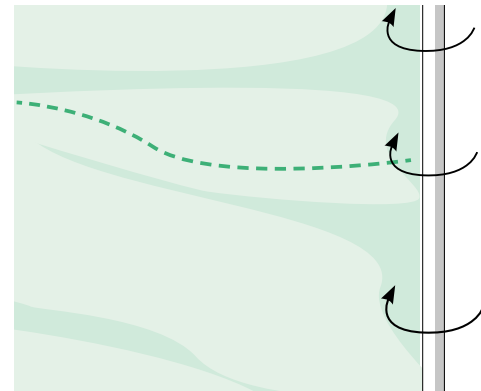



33

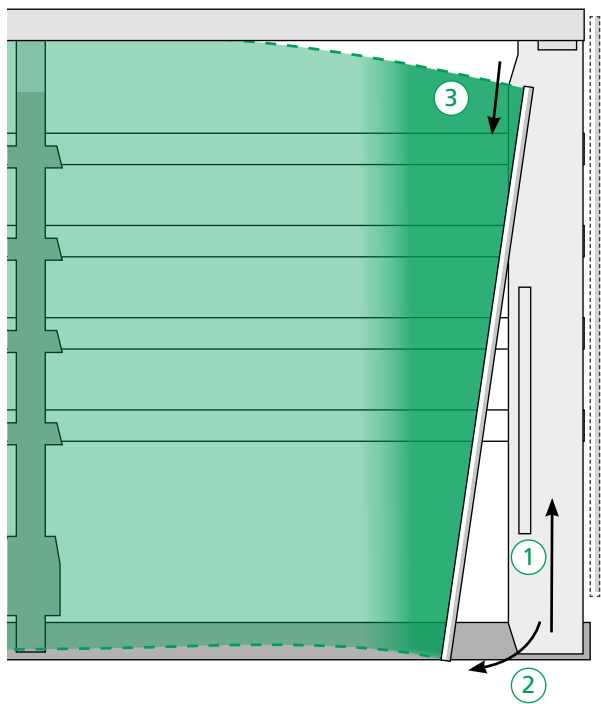

34

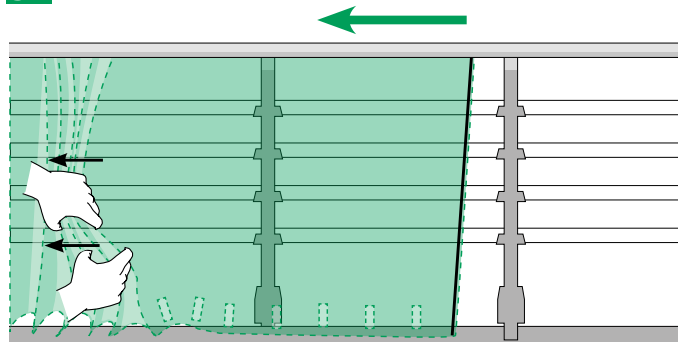

35

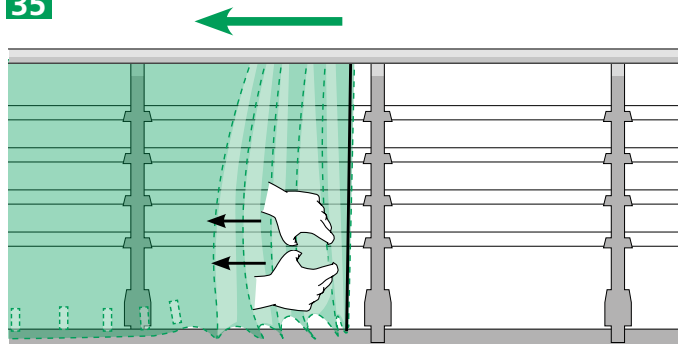

36

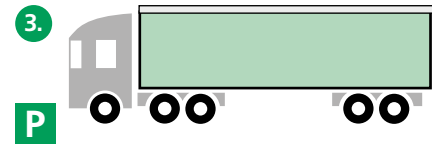
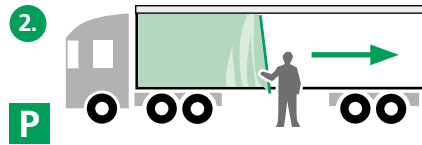
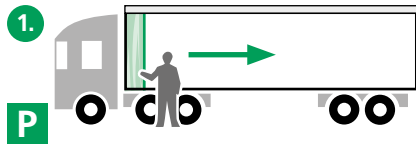

37

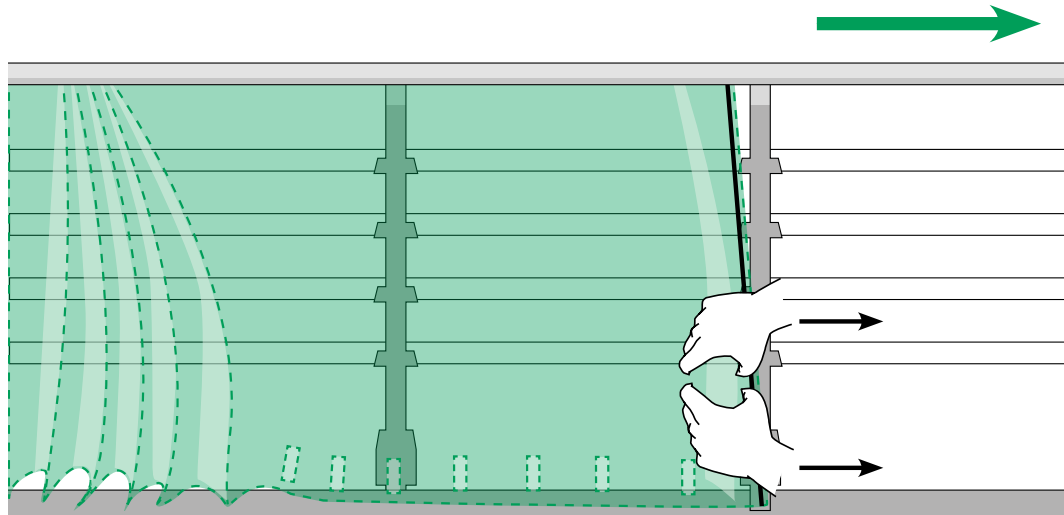



38

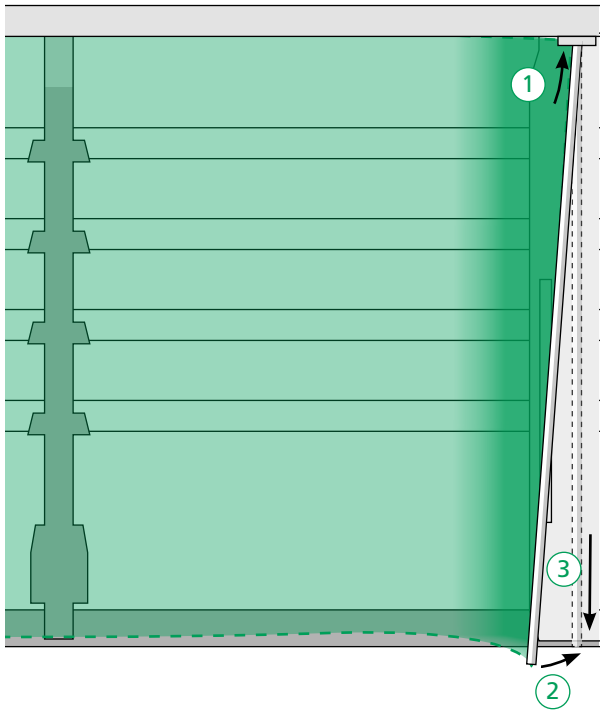

39

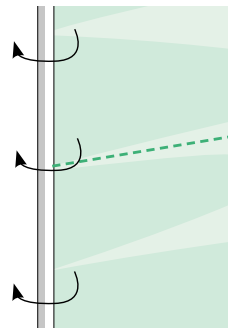

40

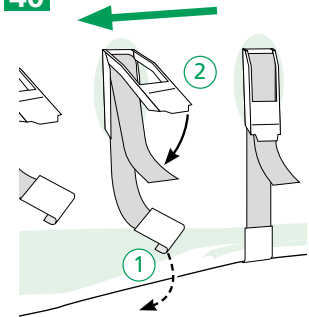

41

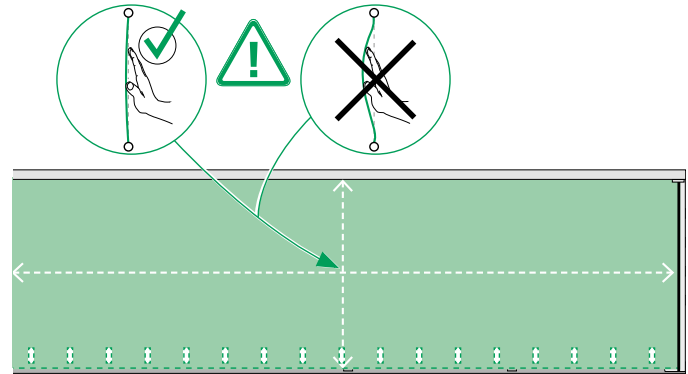

42

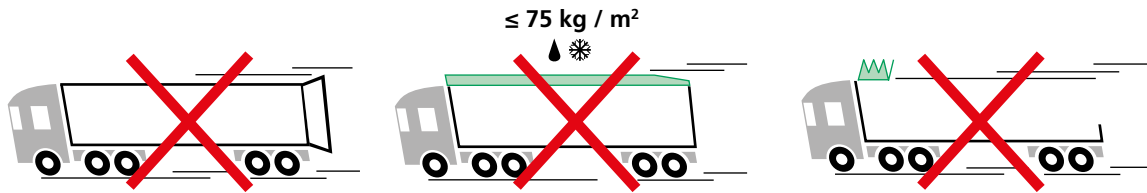

43

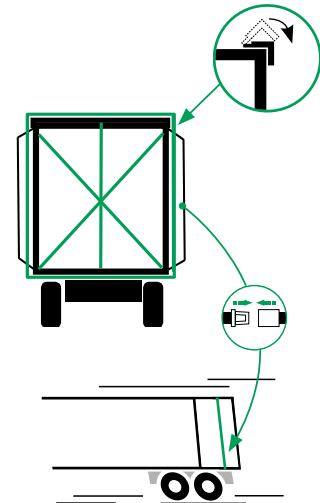
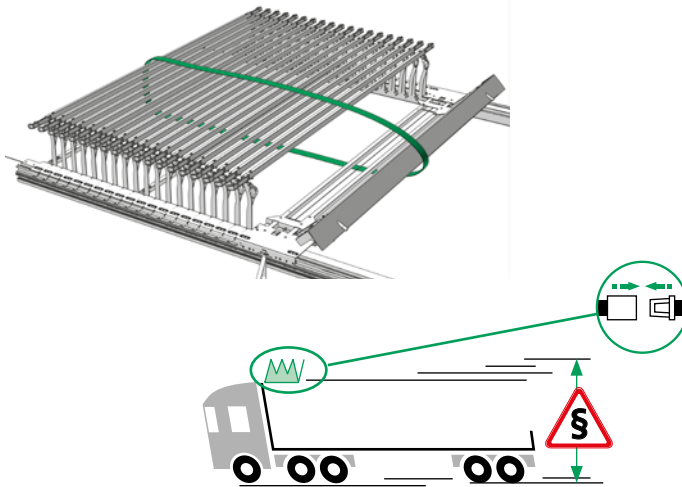

44

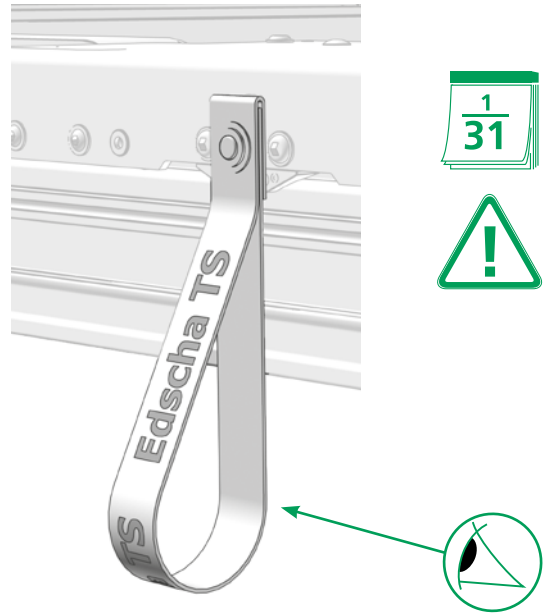
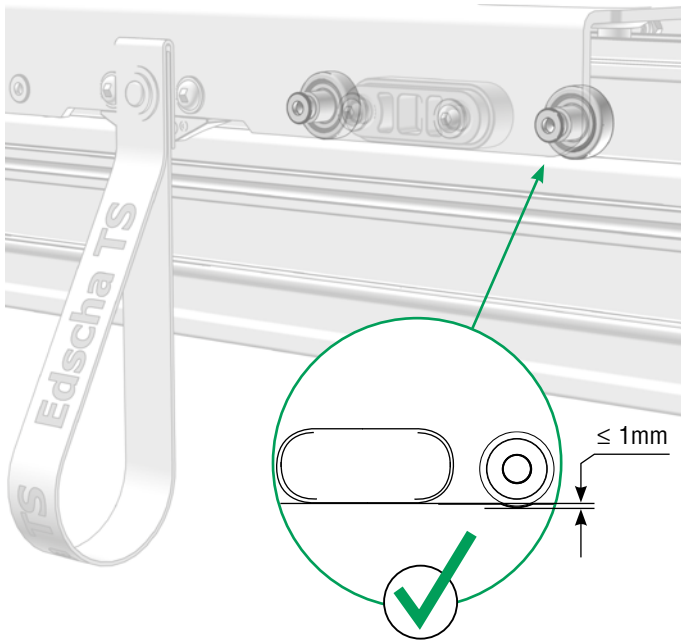

45

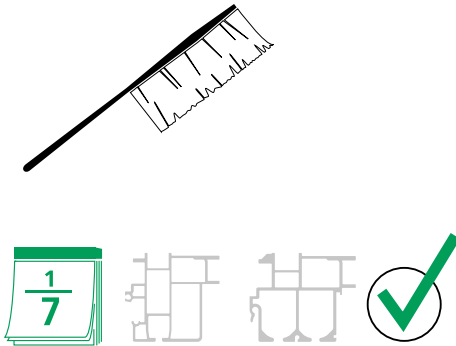
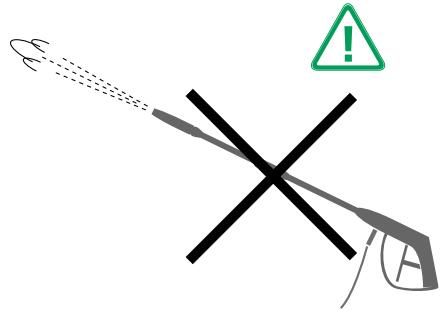

46

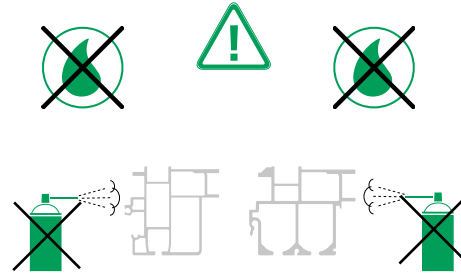

47

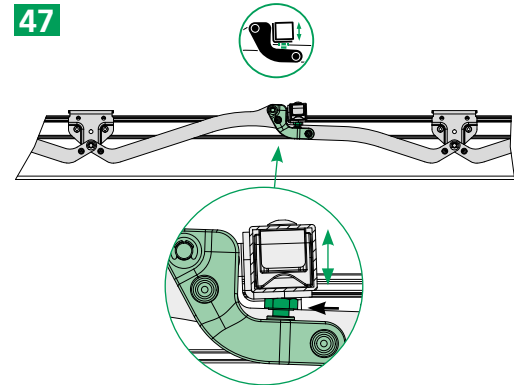



صفحة

2 نظرة عامة على الوظائف  
انزلاقي من جهة واحدة



9 نظرة عامة على الوظائف  
انزلاقي من جهتين



صفحة

3 فتح السقف

6 غلق السقف

10 السقف انزلاقي من جهتين

17 فتح الجانب

19 غلق الجانب

21 القيادة



صفحة

22 الصيانة والعناية



يمكنك العثور على مزيد من المعلومات على  
موقعنا على الإنترنت  
(www.EdschaTS.com)





فهرس المحتويات



الشروحات

الاستخدام المطابق  
للتعليمات

تمييز النوع



نظرة عامة على الوظائف



الاستعمال



الصيانة والعناية



فتح السقف



غلق السقف



انزلاقي من جهتين



فتح الجانب



غلق الجانب



القيادة



يجب إيقاف المركبة!



التأمين بحزام



لا يتم التسخين



1 أسبوعياً



1 شهرياً



يجب المراجعة!



الالتزام باللوائح المحلية



تثبيت صوت مسموع

اسبراي سيليكون أو WD40  
عند الاستخدام: خطر اتساع الغطاء المشمع

فحص بصري



يلزم القفل



قفل عارضة البوابة (اختياري)

أعد ضبط المفصلات إذا كانت  
الأقواس تحك بالقضبان

الوضع

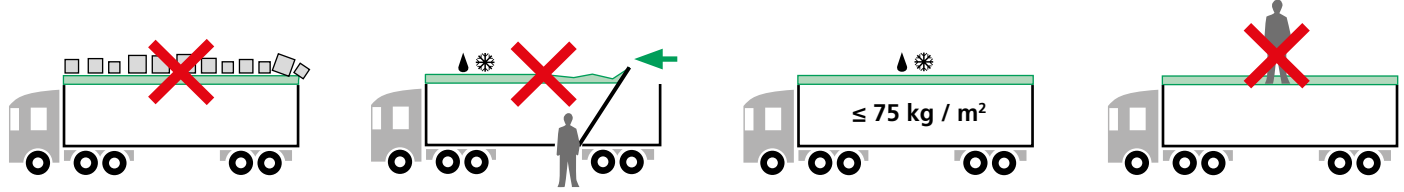

يتم تصنيع الأغطية المشمع المتحركة من شركة Edscha Trailer Systems ومكوناتها التشغيلية حصرياً للاستخدام الموصوف في تطبيقات النقل الخاصة بالشاحنات. وأي استخدام يتجاوز ذلك يعتبر غير مطابق للتعليقات. لا تتحمل الشركة المصنعة Edscha Trailer Systems GmbH، أي مسؤولية من أي نوع عن أي ضرر ناتج عن ذلك، ويتحمل المستخدم وحده المخاطر. يشمل الاستخدام المطابق للتعليقات أيضاً الامتثال لتعليقات التشغيل والصيانة والعناية الخاصة بالشركة المصنعة.



قبل البدء في كل رحلة، يجب فحص السقف المشمع بحثاً عن التلف والتآكل المرئي.

يجب استبدال الأجزاء التالفة والمتآكلة على الفور بأجزاء Edscha Trailer Systems الأصلية.



تنتهي أي مسؤولية تقع على عاتق الشركة المصنعة European Trailer Systems GmbH إذا:

- تم تعديل السقف المشمع الانزلاقي من شركة Edscha Trailer Systems ومكوناته دون تصريح،
- تم استبدال أجزاء Edscha TS الأصلية بمكونات أخرى
- لم يتم تشغيل وصيانة السقف المشمع الانزلاقي من شركة Edscha Trailer Systems ومكوناته التشغيلية وفقاً لتوجيهات شركة Edscha Trailer Systems السارية



يجب مراعاة تشريعات ولوائح الدولة المعنية

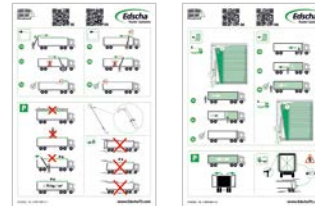

ملصق الاستعمال (يجب لصقه على الشاحنة)

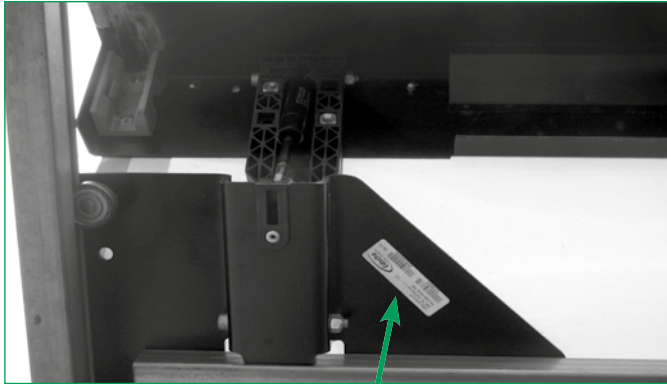

European Trailer Systems GmbH

**Edscha**  
Trailer Systems



113106

رقم السقف المشمع



2342014

نوع السقف المشمع

XX/14

أسبوع الإنتاج

يتم تمييز كل سقف مشمع انزلاقي بلوحة «الرقم التسلسلي» في المصنع. يتم تثبيت لوحة التمييز هذه بالقضيب النهائي (انظر الصورة). يُرجى إرسال طلبك إلى الوكيل أو الشركة المصنعة للمركبة المسؤولة عنك.

يمكنك العثور على مزيد من المعلومات على موقعنا على الإنترنت

(www.EdschaTS.com)

نحتفظ بالحق في إجراء جميع التغييرات الفنية.



دليل التركيب



دليل الإصلاح





**Страница**

Преглед на функцията  
може да се премести на  
една страна 2

Преглед на функцията  
може да се премести на  
двете страни 9



**Страница**

 Отваряне на  
покрива 3

 Затваряне  
напокрива 6

 Покривът се плъзга  
на двете страни 10

 Отваряне на  
страницата 17

 Затваряне на  
страницата 19

 Движение 21

**Страница**

Грижи и поддръжка 22



Допълнителна  
информация ще  
намерите на нашата  
интернет страница  
([www.EdschaTS.com](http://www.EdschaTS.com))



Резюме



Разяснения



Употреба по предназначение



Идентификация на типа



Преглед на функцията



Обслужване



Грижи и поддръжка



Отваряне на покрива



Затваряне на покрива



Плъзга се на двете страни



Отваряне на страницата



Затваряне на страницата



Движение



Превозното средство трябва да е спряно!



Да се обезопасява с ремък



Да не се смазва



1 път седмично



Обърнете внимание!



Да се спазват местните наредби



Да се спазват местните наредби



Веднъж месечно



Силикон спрей или WD40.  
При използване: опасност от замърсяване на брезента



Визуална проверка



Изисква се заключване



Блокировка на портална греда (опция)



Регулирайте ставите, ако дъгтите се търкат в релсите



Позиция

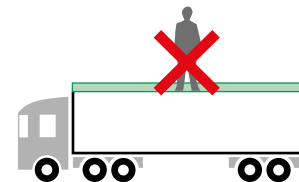
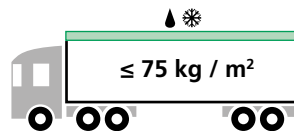
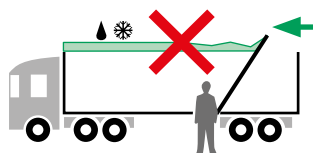
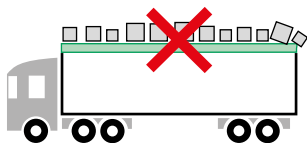

Плъзгачите се гюруци на Edscha Trailer Systems и техните обслужващи компоненти са произведени изключително с цел използване за транспортни цели в товарни автомобили в съответствие с приложимите инструкции. Всяка употреба извън тези граници се счита за употреба не по предназначение. Производителят European Trailer Systems GmbH не поема никаква отговорност за щети, които са възникнали в резултат от това. Рисковете се поемат изцяло от потребителя. Към употребата по предназначение спада и спазването на предписаните от производителя инструкции за обслужване, поддръжка и грижи.



### Отговорността на производителя European Trailer Systems GmbH отпада, ако:

- Плъзгачият се гюрук Edscha Trailer Systems и компонентите му биват самоволно променени.
- оригиналните части на Edscha TS са подменени с други.
- Плъзгачият се гюрук Edscha Trailer Systems и неговите обслужващите компоненти не биват обслужвани и поддържани съгласно ръководните указания на Edscha Trailer Systems.



Преди започване на всяко пътуване гюрукът трябва да бъде проверен за явни повреди и износване.

Дефектните и износените части се подменят незабавно с оригинални части на Edscha Trailer Systems.



Задължително трябва да се спазват законите и наредбите на съответната страна

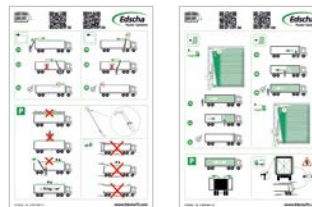

**Стикер за обслужване** (поставя се на камиона)

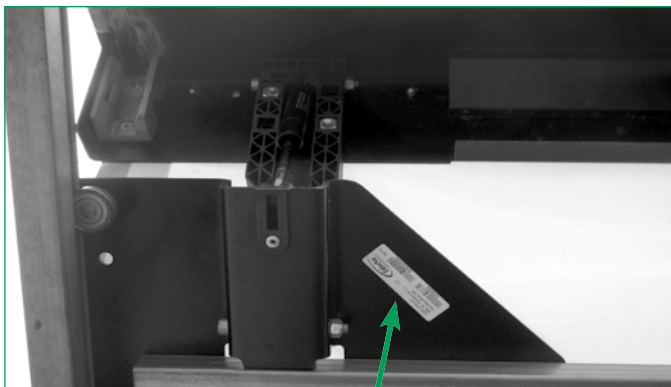

European Trailer Systems GmbH

**Edscha**  
Trailer Systems



113106

Сериен номер



234/2014

Тип покривало

XX/14

Седмица на  
производство

Допълнителна информация ще намерите на нашата интернет страница ([www.EdschaTS.com](http://www.EdschaTS.com))

Запазваме си правото  
на всякакви технически  
промени.



Ръководство за  
монтаж



Ръководство за  
ремонт



Всеки плъзгач се гюрк е обозначен фабрично с табелка „Сериен номер“. Тази маркировка е закрепена на крайния плъзгач (виж изображението). Отправляйте поръчките към Вашия партньор или производителя на превозното средство.



	Strana		Strana		Strana
Přehled funkcí jednostranně posuvné	2	Otevření střechy	3	Údržba a péče	22
Přehled funkcí oboustranně posuvné	9	Zavření střechy	6		
		Oboustranně shrnovací střecha	10		
		Otevření strany	17		
		Zavření strany	19		
		Jízda	21		



Další informace najdete na naší internetové stránce ([www.EdschaTS.com](http://www.EdschaTS.com))





Obsah



Vysvětlivky



Správné používání



Identifikace typu



Přehled funkcí



Obsluha



Údržba a péče



Otevření střechy



Zavření střechy



Oboustranně shrnovací



Otevření strany



Zavření strany



Jízda



Vozidlo musí stát!



Zajistit popruhem



Nemazat olejem



1 x týdně



Jednou měsíčně



Bezpodmínečně dodržujte!



Dodržujte místní předpisy



Slyšitelné zaskočení



Silikonový sprej nebo WD40  
Při použití: nebezpečí znečištění plachty



Vizuální kontrola



Zámek povinný



Zámek nosné konstrukce (volitelný)



Nastavte klouby, když se oblouková vzpěra obrušuje o vedení



pozice

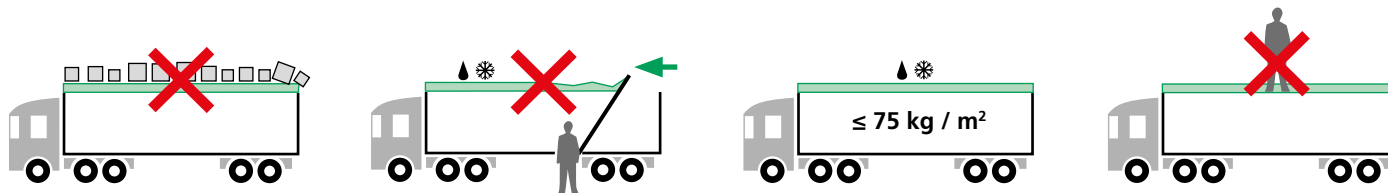

Shrnovací střechy Edscha Trailer Systems a jejich ovládací prvky jsou vyhotoveny jen pro použití v souladu s předpisy pro přepravu nákladů v nákladní dopravě. Každé jiné použití se považuje za použití v rozporu s účelem použití. Výrobce European Trailer Systems GmbH nenese žádnou odpovědnost za takto vzniklé škody, riziko nese samotný uživatel. K správnému použití patří i dodržování výrobcem předepsaných návodů k obsluze, údržbě a na obsluhu, údržbu a ošetřování.



#### Ručení výrobce European Trailer Systems GmbH zaniká, když:

- se provedou svévolné úpravy shrnovací střechy Edscha Trailer Systems, jakož i její součástí;
- se originální díly Edscha-TS vymění za jiné díly
- se obsluha a údržba shrnovací střechy Edscha Trailer Systems, jakož i jejich součástí , neprovádí podle platných směrnic Edscha Trailer Systems



Před každou jízdou je třeba zkontrolovat známky poškození a opotřebení shrnovací střechy.

Chybné a opotřebované díly se musí neprodleně vyměnit za originální díly Edscha Trailer Systems.



**Bezpodmínečně dodržujte předpisy a nařízení příslušné krajiny**

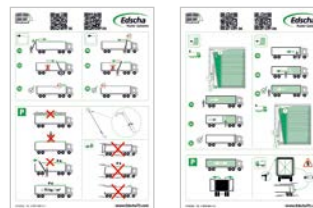

**Nálepka Obsluha (umístit na nákladní vozidlo)**

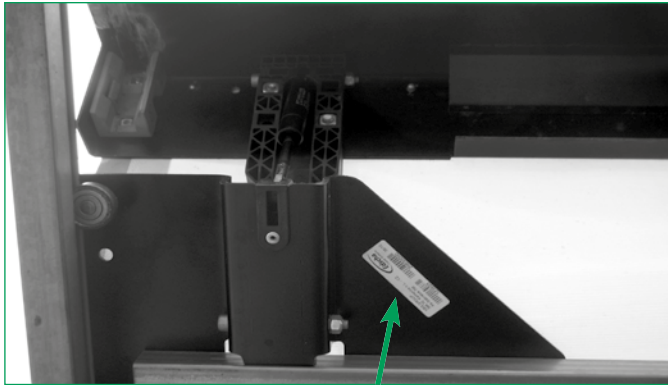

Další informace najdete na naší internetové stránce ([www.EdschaTS.com](http://www.EdschaTS.com))

Všechny technické změny vyhrazeny.



Návod k montáži



Návod k opravě



European Trailer Systems GmbH

113106

2342014

XX/14

Číslo shrnovací střechy

**Typ shrnovací střechy**

Týden výroby

Každá shrnovací střecha je ve výrobě označena štítkem se „sériovým číslem“. Toto označení je upevněno na koncové pohyblivé příčce (viz obrázek). Vaše objednávky posílejte na příslušného partnera nebo na výrobce vozidla.



	Side		Side		Side
Funktionsoversigt kan forskydes i den ene side	2	Tag åbnes	3	Vedligeholdelse og pleje	22
Funktionsoversigt kan forskydes i begge sider	9	Tag lukkes	6		
		Taget kan forskydes fra begge sider	10		
		Side åbnes	17		
		Side lukkes	19		
		Kørsel	21		



Yderligere informationer  
kan findes på vor  
internetside  
**(www.EdschaTS.com)**



Indholds-  
oplysninger



Forklaringer



Tilslaget  
anvendelse



Typeidentifika-  
tion



Funktionsoversigt



Betjening



Vedligeholdelse  
og pleje



Tag åbnes



Tag lukkes



Kan forskydes fra  
på begge sider



Side åbnes



Side lukkes



Kørsel



Køretøjet skal stå  
stille!



Skal sikres med  
rem



Må ikke smøres



1 x ugentligt



En gang om  
måneden



Skal ubetinget  
overholdes!



Lokale forskrifter  
skal overholdes



kommes hørbart i  
indgreb



Silikonespray eller WD40  
Ved indsats: fare for tilslagsning  
af pressening



visuel kontrol



Aflåsning  
nødvendig



Portalbjækelås  
(valgfri)



Efterjustér leddene,  
hvis bøjlerne slæber  
på skinnerne



Position

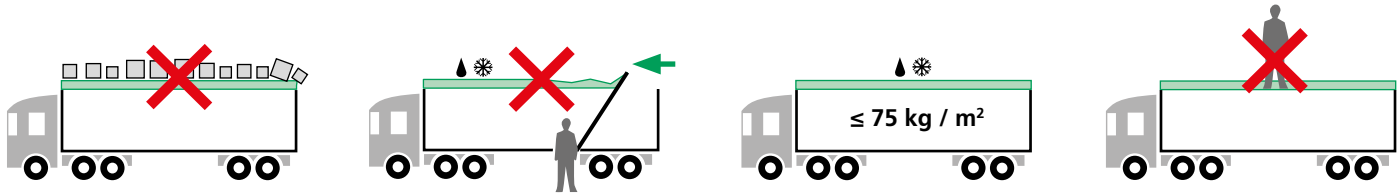

Skydetagene fra Edscha Trailer Systems og disses servicekomponenter er lavet udelukkende til en forskriftsmæssig anvendelse ved lastbilspecifikke transportindsatser. Enhver anden brug, der går herudover, betragtes som utilsigtet. For skader, der er et resultat heraf, fraskriver producenten European Trailer Systems GmbH sig ethvert ansvar, alle risici sker på brugerens egen regning. Til tilsigtet anvendelse hører også overholdelse af de betjenings-, vedligeholdelses- og plejeinstruktioner, som kommer fra producenten side.



### Ethvert ansvar fra producentens side, European Trailer Systems GmbH, bortfalder, hvis:

- Hvis skydetage fra Edscha Trailer Systems samt disses komponenter ændres på uautoriseret vis;
- Edscha Trailer Systems skydetagssystem såvel som dets komponenter er blevet ombygget
- Hvis skydetage fra Edscha Trailer Systems samt disses betjeningskomponenter ikke betjenes og vedligeholdes efter gældende



Før man starter op, skal man kontrollere overdækningen for tegn på skader og slid.

Defekte og slidte dele skal omgående udskiftes med originale dele fra Edscha Trailer Systems.



Bestemmelserne og forskrifterne, der er gældende i de enkelte lande, skal respekteres

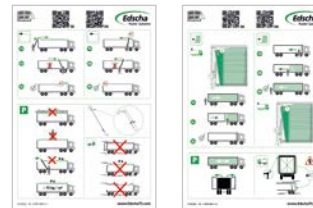

Brug af stickere (sættes på truck)

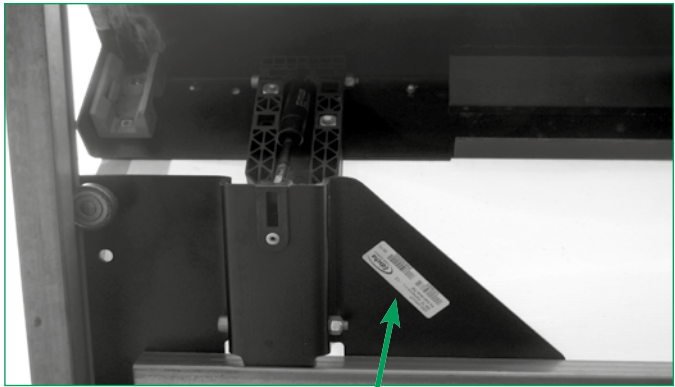

Yderligere informationer kan findes på vor hjemmeside ([www.EdschaTS.com](http://www.EdschaTS.com))

Alle tekniske ændringer forbeholdes.

Monteringsvejledning

Reparationsvejledning



European Trailer Systems GmbH



113106

234|2014

XX/14

Presseningnummer

**Presseningtype**

Produktionsuge

Hvert skydetag er fra fabrikkens side markeret med et skilt „serienummer“. Dette skilt er sat fast på slutvognen (se figur). Hvad angår ordren, så kontakt venligst den lokale forhandler eller producenten.



	Seite		Seite		Seite
Funktionsübersicht einseitig verschiebbar	2	Dach öffnen	3	Wartung und Pflege	22
Funktionsübersicht beidseitig verschiebbar	9	Dach schließen	6		
		Dach beidseitig verschiebbar	10		
		Seite öffnen	17		
		Seite schließen	19		
		Fahren	21		



Weitere Informationen finden Sie auf unserer Internetseite ([www.EdschaTS.com](http://www.EdschaTS.com))





Inhaltsangabe



Erklärungen



Bestimmungsgemäße Verwendung



Typidentifizierung



Funktionsübersicht



Bedienung



Wartung und Pflege



Dach öffnen



Dach schließen



Beidseitig verschiebbar



Seite öffnen



Seite schließen



Fahren



Fahrzeug muss stehen!



Mit Gurt sichern



Nicht fetten



1 x wöchentlich



1 x monatlich



Unbedingt beachten!



Örtliche Vorschriften einhalten



Hörbares Einrasten



Silikonspray oder WD40  
Bei Einsatz: Gefahr der Planen-  
verschmutzung



Visuelle Kontrolle



Verriegeln erforderlich



Portalbalken Verriegelung (optional)



Gelenke nachstellen, falls Spriegel auf den Schienen schleifen



Position

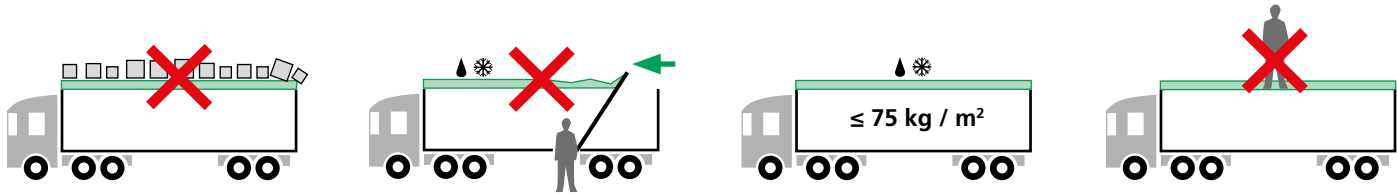

Die Edscha Trailer Systems Schieberverdecke und deren Bedienungsbauteile sind ausschließlich für den vorschriftsmäßigen Einsatz bei lastwagenspezifischen Transporteinsätzen gefertigt. Jeder darüber hinausgehende Gebrauch gilt als nicht bestimmungsgemäß. Für hieraus resultierende Schäden lehnt der Hersteller European Trailer Systems GmbH jegliche Haftung ab, Risiken hierzu trägt allein der Benutzer. Zur bestimmungsgemäßen Verwendung gehört auch die Einhaltung der vom Hersteller vorgeschriebenen Bedienungs-, Wartungs- und Pflegeanweisungen.



### Jegliche Haftung des Herstellers European Trailer Systems GmbH erlischt, wenn:

- das Edscha Trailer Systems Schieberverdeck sowie dessen Bauteile eigenmächtig verändert werden;
- Edscha-TS-Originalteile gegen andere Bauteile ausgewechselt werden
- Das Edscha Trailer Systems Schieberverdeck sowie dessen Bedienungsbauteile nicht nach den gültigen Edscha Trailer Systems Richtlinien bedient und gewartet werden



Vor Antritt jeder Fahrt ist das Verdeck auf erkennbare Beschädigungen und Verschleiß zu überprüfen.

Defekte und abgenutzte Teile sind umgehend gegen Edscha Trailer Systems Originalteile auszutauschen.



**Bestimmungen und Vorschriften des jeweiligen Landes sind unbedingt einzuhalten**

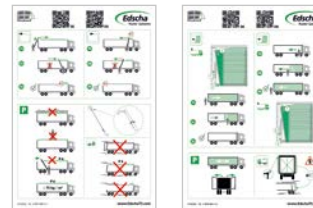

**Aufkleber Bedienung (Anzubringen am LKW)**

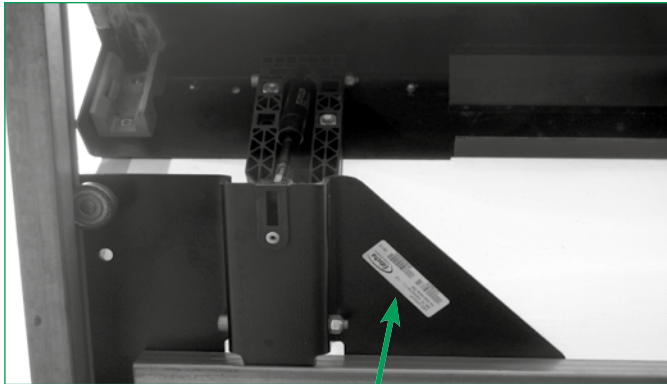

European Trailer Systems GmbH



113106

Verdecknummer



234|2014

Verdecktyp

XX/14

Produktionswoche

Weitere Informationen finden Sie auf unserer Internetseite  
([www.EdschaTS.com](http://www.EdschaTS.com))

Alle technischen Änderungen  
vorbehalten.



Montageanleitung



Reparaturanleitung



Jedes Schiebeerdeck ist werkseitig mit einem Schild „Seriennummer“ gekennzeichnet. Diese Kennzeichnung ist auf dem Endlaufwagen (siehe Abbildung) befestigt. Ihre Bestellung richten Sie bitte an den für Sie zuständigen Partner oder Fahrzeugbauer.



Πλευρά

Συνοπτική παρουσίαση λειτουργίας δυνατότητα μονόπλευρης μετατόπισης 2

Συνοπτική παρουσίαση λειτουργίας δυνατότητα αμφίπλευρης μετατόπισης 9



Πλευρά

Άνοιγμα οροφής 3

Κλείσιμο οροφής 6

Οροφή συρόμενη και από τις δύο πλευρές 10

Πλευρικό άνοιγμα 17

Πλευρικό κλείσιμο 19

Οδήγηση 21



Πλευρά

Συντήρηση και φροντίδα 22

Περισσότερες πληροφορίες μπορείτε να βρείτε στην ιστοσελίδα μας ([www.EdschaTS.com](http://www.EdschaTS.com))



Αναφορά  
περιεχομένου



Δηλώσεις



Προβλεπόμενη  
χρήση



Ταυτοποίηση  
τύπου



Συνοπτική  
παρουσίαση  
λειτουργίας



Χειρισμός



Συντήρηση και  
φροντίδα



Άνοιγμα οροφής



Κλείσιμο οροφής



Συρόμενη και από  
τις δύο πλευρές



Πλευρικό άνοιγμα



Πλευρικό  
κλείσιμο



Μετακίνηση



Το όχημα θα  
πρέπει να είναι  
ακίνητο!



Ασφάλιση με  
ζώνη



Μη βάζετε λάδι



1 x την  
εβδομάδα



Μια φορά  
το μήνα



Να λαμβάνεται  
οπασδήποτε  
υπόψη!



να τηρείτε τις  
κατά τόπους  
διατάξεις



Αισθητό  
κούμπωμα



Σιλικόνη σπρέι ή WD40  
Κατά την εφαρμογή: Κίνδυνος  
λερώματος



οπτικός  
έλεγχος



Το κλείδωμα είναι  
απαραίτητο



Κλείδωμα δοκού  
με ανάρτηση  
(προαιρετικό)



Αναπροσαρμόστε  
τις αρθρώσεις εάν τα  
τόξα σύρονται στις  
ράγες



Θέση

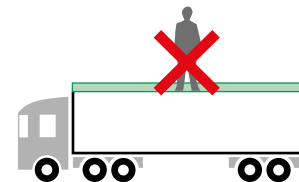
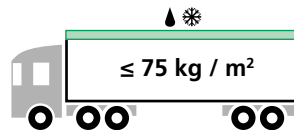
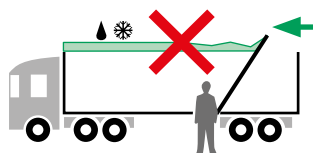
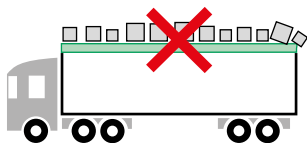

Οι συρόμενες οροφές της Edscha Trailer Systems και τα εξαρτήματά τους κατασκευάζονται αποκλειστικά για την προβλεπόμενη χρήση σε ειδικές εφαρμογές μεταφοράς με φορτηγά. Κάθε χρήση πέραν αυτής θεωρείται ως μη προβλεπόμενη. Για ζημιές που προκαλούνται εξ' αυτού ο κατασκευαστής European Trailer Systems GmbH αποκλείει κάθε ευθύνη, ενώ τους σχετικούς κινδύνους τους αναλαμβάνει ο χειριστής. Στην προβλεπόμενη χρήση συμπεριλαμβάνεται και η τήρηση των οδηγιών χειρισμού, συντήρησης και φροντίδας που προβλέπονται από τον κατασκευαστή.



**Κάθε ευθύνη του κατασκευαστή European Trailer Systems GmbH αίρεται, εφόσον:**

- η συρόμενη οροφή της Edscha Trailer Systems, καθώς και τα εξαρτήματά της τροποποιούνται αυθαίρετα
- Τα γνήσια εξαρτήματα Edscha-TS αντικατασταθούν από άλλα εξαρτήματα
- η συρόμενη οροφή της Edscha Trailer Systems καθώς και τα εξαρτήματα χειρισμού της δεν χειρίζονται και δεν συντηρούνται σύμφωνα με τις ισχύουσες οδηγίες της Edscha Trailer Systems



Πριν από την εκκίνηση κάθε διαδρομής, η οροφή θα πρέπει να ελέγχεται για ζημιές και φθορές. Τα χαλασμένα και φθαρμένα εξαρτήματα θα πρέπει να αντικαθίστανται άμεσα με γνήσια εξαρτήματα Edscha Trailer Systems.



Οι όροι και οι διατάξεις του κάθε κράτους θα πρέπει να τηρούνται οπωσδήποτε

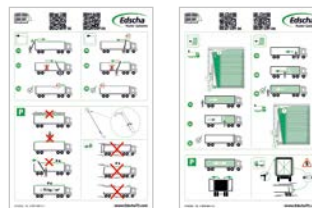

**Αυτοκόλλητο οδηγιών χειρισμού (Τοποθετείται στο φορτηγό)**

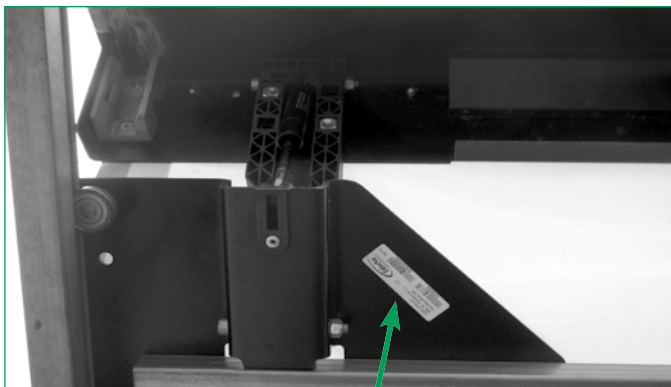

European Trailer Systems GmbH

**Edscha**  
Trailer Systems



113106

Αριθμός καλύμματος



2342014

Τύπος καλύμματος

XX/14

Εβδομάδα παραγωγής

Περισσότερες πληροφορίες μπορείτε να βρείτε στην ιστοσελίδα μας ([www.EdschaTS.com](http://www.EdschaTS.com))

Με επιφύλαξη για τυχόν τεχνικές τροποποιήσεις.



Οδηγίες συναρμολόγησης



Οδηγίες επισκευής



Κάθε συρόμενη οροφή επισημαίνεται από το εργοστάσιο με μια πινακίδα με τον “αύξοντα αριθμό”. Αυτή η σήμανση στερεώνεται στην τελευταία ράγα (βλέπε απεικόνιση). Την παραγγελία σας παρακαλούμε να την απευθύνετε στο συνεργάτη που είναι υπεύθυνος για σας, ή στον κατασκευαστή του οχήματος.



	Page		Page		Page
Overview of use Slides one way	2	Roof opening process	3	Care and maintenance	22
Overview of use Slides one way	9	Roof closing process	6		
		Roof slidable on both sides	10		
		Open side	17		
		Close side	19		
		Driving	21		



For further information please refer to our website  
[\*\*\(www.EdschaTS.com\)\*\*](http://www.EdschaTS.com)





Content



Explanations



Intended usage



Type identification



Overview of use



Operation



Care and maintenance



Roof opening



Roof closing



Slidable on both sides



Open side



Close side



Driving



Vehicle must stand!



Lock with belt



Do not oil



Once per week



Once per month



Please note without fail!



Note local rules and regulations



Clicking sound



Silicone spray or WD40  
By using: risk of tarpaulin pollution



Visual inspection



Locking is necessary



Gantry beam lock (optional)



Adjust joints appropriately if bows chafe on fittings



Position

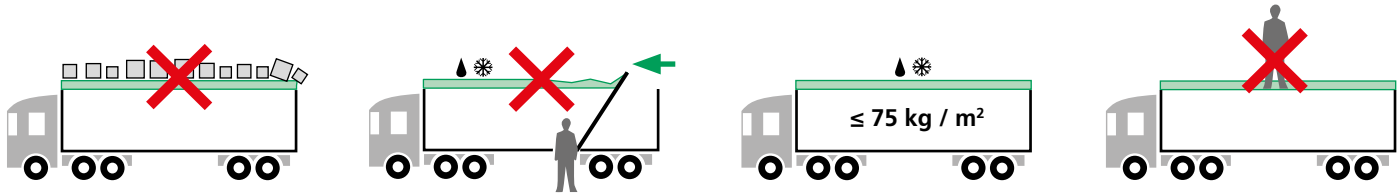

The Edscha Trailer Systems sliding roofs and their operating components are exclusively manufactured for use in truck-specific transport operations in accordance with applicable instructions. Any usage not in conformity with the applicable instructions is considered a misuse. No liability will be assumed by the manufacturer for this; the user alone bears the full risk. The “intended usage” also includes the observance of the operation, care and maintenance instructions, as prescribed by the manufacturer.



**The manufacturer, European Trailer Systems GmbH, is discharged from any liability if:**

- the Edscha Trailer Systems sliding roof and its components are changed arbitrarily
- Edscha-TS original parts are replaced with other components;
- the Edscha Trailer Systems sliding roof and its operating components are not handled and serviced in compliance with the applicable Edscha Trailer Systems instructions



The sliding roof must be inspected for visible damage and wear and tear before beginning each journey

Defective or worn parts must be replaced immediately with original Edscha Trailer Systems parts.



**Rules and regulations of the respective country must be respected**

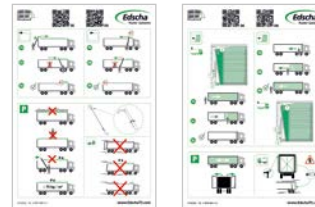

**Sticker Operation** (apply on truck)

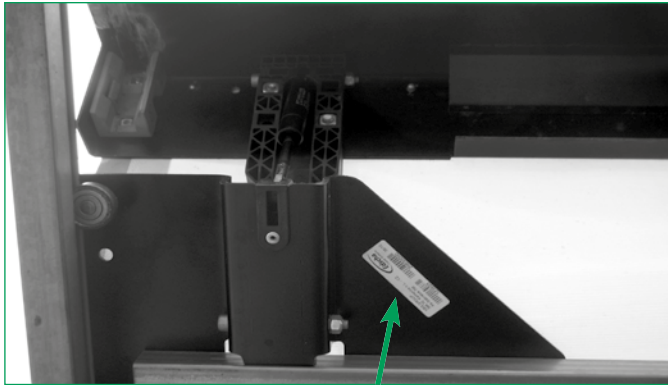

European Trailer Systems GmbH

113106      234|2014      XX/14

serial number

roof type

week of manufacture

For further information please go to our website  
**(www.EdschaTS.com)**

Subject to technical changes.



Assembly instructions



Repair instructions



Every sliding roof is provided in the factory with a sign „serial number“. This sign is attached to the end carriage (see figure). Send your order to relevant partner in your area or to the vehicle manufacturer.



Vista general de funcionamiento Desplazable por un lado 2



Abrir la cubierta 3

Vista general de funcionamiento Desplazable por ambos lados 9



Cerrar la cubierta 6



Cubierta desplazable a ambos lados 10



Abrir lateral 17



Cerrar lateral 19



Conducción 21

Limpieza y mantenimiento 22



Encontrará información en nuestra página de Internet **(www.EdschaTS.com)**



Resumen



Explicaciones



Utilización  
conforme al uso  
previsto



Identificación de  
tipo



Vista general de  
funcionamiento



Manejo



Limpieza y  
mantenimiento



Abrir la cubierta



Cerrar la cubierta



Desplazable a  
ambos lados



Abrir lateral



Cerrar lateral



Conducción



¡El vehículo debe  
estar parado!



Asegurar con  
correas



No lubricar



Una vez a  
la semana



Una vez  
al mes



¡Cumplir  
obligatoriamente!



Observar las  
normativas locales



Encajar bien



WD 40 o spray de silicona en caso de  
utilización: pone en peligro el medio  
ambiente.



Control visual



Cierre obligatorio



Cierre del brazo  
del pórtico  
(opcional)



Ajustar la articula-  
ción en caso de que  
los arcos desbasten  
sobre los carriles



Posición

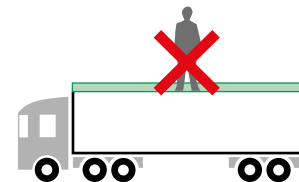
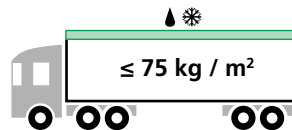
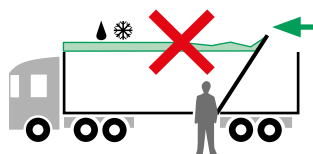
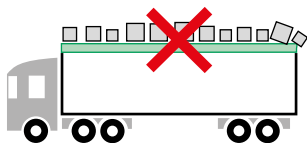

Las cubiertas corredizas Edscha TS y sus componentes de servicio están exclusivamente fabricados para utilizarse en transportes específicos de camiones. Cualquier otra utilización se considerará no conforme al uso previsto. La empresa fabricante European Trailer Systems GmbH declina cualquier tipo de responsabilidad derivada de un mal uso del producto, cuyo riesgo asumirá el usuario. Dentro de una utilización conforme al uso previsto, se incluye también la obligación de cumplir con las indicaciones de manejo, limpieza y mantenimiento contenidas en el manual del fabricante.



**European Trailer Systems GmbH declina toda responsabilidad en los siguientes casos:**

- si la cubierta corrediza de Edscha TS o sus componentes fueran modificados sin permiso,
- si se cambiaran las piezas originales de Edscha TS por otras,
- si la cubierta corrediza de Edscha TS o sus componentes de servicio no se manejaran ni se mantuvieran tal y como lo prescriben las normativas de Edscha Trailer Systems



Antes de iniciar cada viaje, hay que comprobar que la cubierta no sufra desperfectos ni desgastes.

Reemplace de inmediato las piezas defectuosas o desgastadas por otras originales de Edscha Trailer Systems.



**Es obligatorio cumplir con las normas y reglamentos del país correspondiente.**

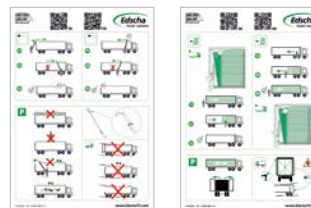

**Pegatinas de manejo (colocar en el camión)**

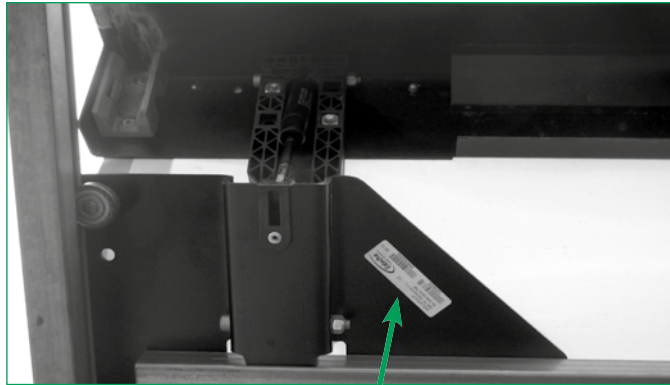

Encontrará información en nuestra página de Internet ([www.EdschaTS.com](http://www.EdschaTS.com))

Reservado el derecho a realizar todo tipo de modificaciones técnicas.



Instrucciones de montaje



Instrucciones de reparación



European Trailer Systems GmbH

113106      234|2014      XX/14

Número de cubierta

**Tipo de cubierta**

Semana de producción

Cada cubierta corrediza lleva incorporada de fábrica una placa con su número de serie. Esta placa se encuentra fijada al final del carro de la guía (véase imagen). Realice su pedido al socio o fabricante de vehículos correspondiente.



Lehekülg

Funktsioonide ülevaade  
ühele poole liigutatav 2

Funktsioonide ülevaade  
mõlemale poole liigutatav 9



Lehekülg

Katuse avamine 3

Katuse sulgemine 6

Mõlemalt poolt  
liigutatav katus 10

Külje avamine 17

Külje sulgemine 19

Sõit 21



Lehekülg

Hooldus ja puhastamine 22

Lisainfo meie  
kodulehelt  
**(www.EdschaTS.com)**





Andmed sisu kohta



Selgitused



Sihipärane kasutamine



Tüübi tuvastamine



Funktsioonide ülevaade



Kasutamine



Hooldus ja puhastamine



Katuse avamine



Katuse sulgemine



Mõlemalt poolt liigutatav



Külje avamine



Külje sulgemine



Sõit



Sõiduk peab seisma!



Rihmaga fikseerida



Mitte õlitada



1 x nädalas



Kord kuus



Kindlasti järgida!



Pidage kinni kohapeal kehtivatest eeskirjadest



Kuuldav fikseerimine



Silikon Spray või WD40 Kasutamisel: presentkatte määrdumise oht



Visuaalne kontroll



Lukustus nõutav



Sillatala lukustus (valikuline)



Reguleerige ühendusi, kui kaared siinide vastu hõõrduvad



Asend

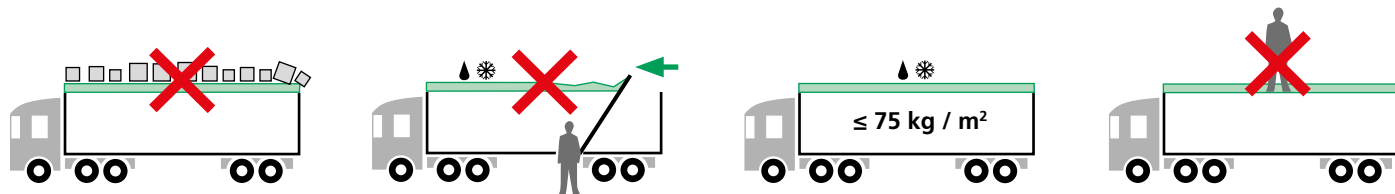

Edscha Trailer Systems liugkatted ja nende komponendid on ette nähtud eranditult eeskirjadekohaseks kasutamiseks ühenduses veoautodel toimuvate veostega. Igasugust neist raamidest väljuvat kasutamist loetakse mittesihipäraseks. Tootja European Trailer Systems GmbH ei vastuta sellest tulenevate kahjude eest ja kogu risk lasub ainuüksi kasutajal. Sihipärase kasutamise hulka kuulub ka tootja poolt ettenähtud kasutus-, hooldus- ja puhastusjuhiste järgimine.



**Tootjafirma European Trailer Systems GmbH igasugune vastutus kustub, kui:**

- Edscha Trailer Systems liugkattet ning selle komponente muudetakse omavoliliselt.
- Edscha-TS-originaalosad asendatakse muude komponentidega.
- Edscha Trailer Systems liugkattet ning selle komponente ei kasutata ja hooldata vastavalt firma Edscha Trailer Systems kehtivatele juhistele.



Iga kord enne sõidu alustamist tuleb kontrollida, et kattel ei ole kahjustusi ja kulunud kohti.

Defektsed ja kulunud osad tuleb kohe asendada Edscha Trailer Systems'i originaalosadega.



**Riigis kehtivatest määrustest ja eeskirjadest tuleb kindlasti kinni pidada.**

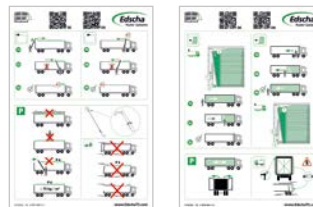

**Kleebis Kasutamine (paigaldada veoautole)**

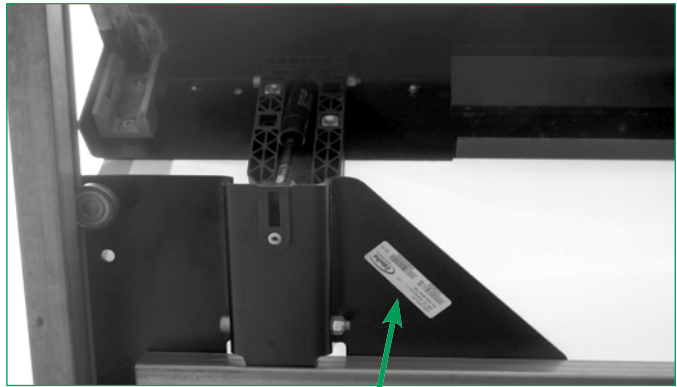

Lisainfo meie kodulehelt  
**(www.EdschaTS.com)**  
 Jätame endale õiguse teha  
 tehnilisi muudatusi.

European Trailer Systems GmbH

113106

234|2014

XX/14

Katte number

**Katte tüüp**

Valmistamise nädal



Montaažijuhend



Remondijuhend



Iga lükandkate on tehasepoolselt tähistatud sildiga „Seerianumber“. See tähis on kinnitatud tagumisele liugtoele (vt joonist). Palun saatke oma tellimus pädevale partnerile või sõidukitootjale.



	Sivu		Sivu		Sivu
Toimintojen yleiskatsaus liikuteltavissa yhdeltä puolelta	2	Katon aukai	3	Huolto ja hoito	22
Toimintojen yleiskatsaus liikuteltavissa molemmin puolin	9	Katon sulkeminen	6		
		Katto liikuteltavissa molempiin suuntiin	10		
		Sivun aukaisu	17		
		Sivun sulkeminen	19		
		Ajaminen	21		



Lisätietoa löytyy internet-sivuiltamme  
**(www.EdschaTS.com)**



Sisältö



Selitykset



Määrästen-  
mukainen käyttö



Tyyppimerkintä



Toimintojen yleis-  
katsaus



Käyttö



Huolto ja  
hoito



Katon aukaisu



Katon sulkeminen



Liikuteltavissa  
molempiin  
suuntiin



Sivun aukaisu



Sivun sulkeminen



Ajaminen



Ajoneuvon  
oltava pysäköity!



Varmista vöillä



Ei saa öljyä



1 x viikossa



Kerran  
kuukaudessa



Ehdottomasti  
huomioitava!



Noudata paikallisia  
määräyksiä



Lukittuminen  
kuuluvasti



Silikonisuihke tai WD40 Käytössä:  
Vaarana pressun likaantuminen



Ulkopuolinen  
tarkastus



Lukitseminen  
välttämätöntä



Portaalipalkin  
lukitus  
(valinnainen)



Säädä niveliä, jos  
tukikaaret hankaavat  
kiskoja vasten



Asento

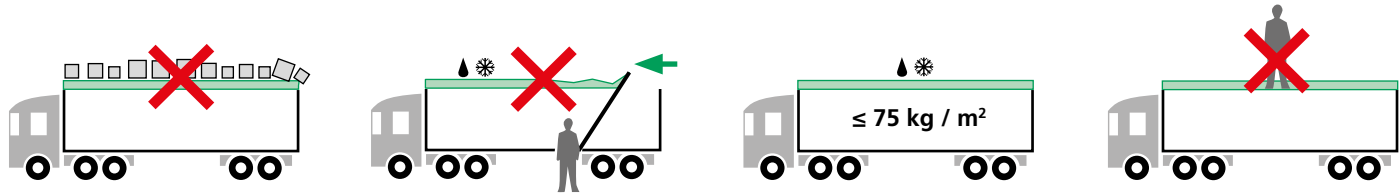

Edscha Trailer Systems -liukukatot ja niiden käyttöosat on tarkoitettu ainoastaan määräystenmukaiseen käyttöön rekka- ja kuorma-autojen kuljetuskäytössä. Kaikki sen ylittävä käyttö katsotaan määräystenvastaiseksi. Valmistaja, European Trailer Systems GmbH, ei vastaa millään tavoin näin syntyneistä vahingoista, käyttäjä yksin vastaa tällöin riskeistä. Määräystenmukaiseen käyttöön kuuluu myös valmistajan ohjeisiin kuuluvien käyttö-, huolto- ja hoito-ohjeiden noudattaminen.



**Valmistajan, European Trailer Systems GmbH -yhtiön, vastuu raukeaa, jos:**

- Edscha Trailer Systems -liukukattoa ja sen käyttöosia muutetaan ilman lupaa;
- Edscha-TS-alkuperäisosien tilalle vaihdetaan muita osia
- Edscha Trailer Systems -liukukattoa ja sen käyttöosia ei käytetä eikä huolleta voimassa olevien Edscha Trailer Systems -ohjesääntöjen mukaisesti



Ennen jokaista ajoa tulee tarkistaa, onko katossa vaurioita tai kulumia.

Vialliset ja kuluneet osat on vaihdettava välittömästi Edscha Trailer Systems -alkuperäisosiin.



**Kunkin maan asetuksia ja määräyksiä on ehdottomasti noudatettava**

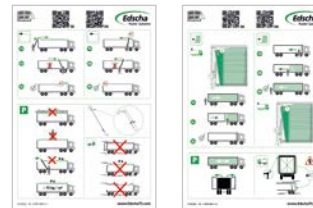

**Käyttöä koskeva tarra (kiinnitetään kuorma-autoon)**

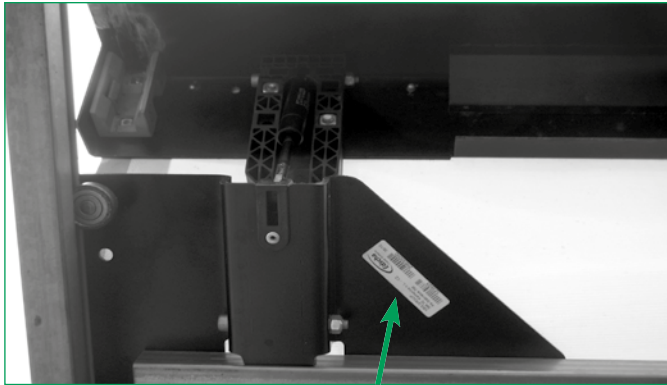

European Trailer Systems GmbH



113106



2342014

XX/14

Suojapeitteen  
numero

Suojapeitetyyppi

Tuotantoviikko

Lisätietoa löytyy internet-sivuiltamme  
([www.EdschaTS.com](http://www.EdschaTS.com))

Pidätämme oikeuden kaikkiin  
teknisiin muutoksiin.



Asennusohje



Korjausohje



Jokainen liukukatto on merkitty tehtaalla kilvellä „Sarjanumero“. Tämä merkintä on kiinnitetty kiskovaunun päähän (katso kuvaa). Tilaus osoitetaan lähimmälle edustajalle tai ajoneuvojen muutos- ja varustelutöitä tekeväälle yritykselle.



Page  
Aperçu des fonctions  
déplaçable sur un côté 2



Ouvrir le toit 3

Page  
Aperçu des fonctions  
déplaçable sur les  
deux côtés 9



Fermer le toit 6



Toit coulissant des  
deux côtés 10



Ouvrir le côté 17



Fermer le côté 19



Conduite 21

Page  
Maintenance et entretien 22



Vous trouverez de plus  
amples informations sur  
notre site internet  
**(www.EdschaTS.com)**





Contenu



Explications



Utilisation  
conforme



Identification  
du type



Aperçu des fon-  
ctions



Commande



Maintenance  
et entretien



Ouvrir le toit



Fermer le toit



Couissant des  
deux côtés



Ouvrir le côté



Fermer le côté



Conduite



Le véhicule doit  
être à l'arrêt !



Sécuriser au  
moyen d'une  
sangle



Ne pas lubrifier



1 x par  
semaine



Une fois par  
mois



À respecter  
absolument !



Respecter les dis-  
positions locales



Verrouillage  
audible



WD40 ou Silicone Spray  
Lors de l'utilisation :  
risque de salir la bâche



Contrôle visuel



Verrouillage  
nécessaire



verrouillage de  
traverse de pont  
roulant (option)



Réajuster les joint-  
tures si les arceaux  
frottent sur les rails



Position

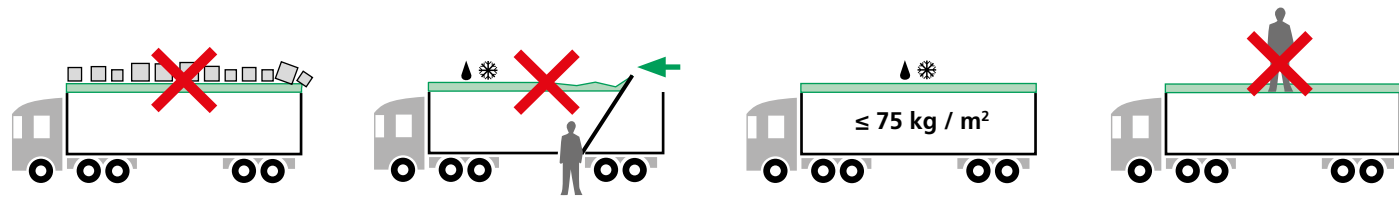

Les toits coulissants Edscha Trailer Systems et leurs éléments de manipulation sont exclusivement destinés à une utilisation conforme à l'affectation pour des opérations de transport spécifiques au camion. Toute autre utilisation sera considérée comme non conforme à l'affectation et dégagea le constructeur European Trailer Systems GmbH de toute responsabilité en cas de préjudice. L'utilisateur supportera seul les risques résultant d'une telle utilisation. L'utilisation conforme à l'affectation implique également le respect des consignes d'opération, de maintenance et d'entretien telles que prescrites par le constructeur.



Vérifier le toit afin d'exclure tout endommagement et usure visibles avant chaque départ.

Toute pièce défectueuse ou usée doit être immédiatement remplacée par une pièce d'origine Edscha Trailer Systems.



**La responsabilité du constructeur European Trailer Systems GmbH ne pourra être engagée si :**

- le toit coulissant Edscha Trailer Systems et ses composants sont modifiés sans concertation préalable avec le constructeur
- les pièces d'origine Edscha-TS sont remplacées par d'autres pièces
- le toit coulissant Edscha Trailer Systems et ses éléments de manipulation ne sont pas manipulés ou entretenus conformément aux directives d'Edscha Trailer Systems



**Les dispositions et directives locales doivent être absolument respectées.**

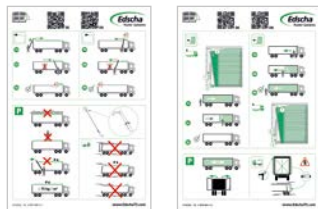

**Autocollant utilisation (à apposer sur le poids-lourd)**

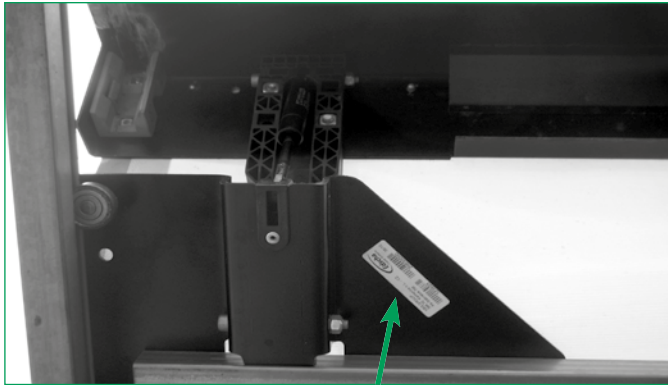

Vous trouverez de plus amples informations sur notre site internet ([www.EdschaTS.com](http://www.EdschaTS.com))  
Sous réserve de modifications techniques.

European Trailer Systems GmbH

113106      234|2014      XX/14

Référence du bâchage

Type de bâchage

Semaine de production

Chaque toit coulissant est doté, en usine, d'un panneau « numéro de série ». Ce panneau est fixé sur le rail coulissant arrière (voir figure). Veuillez envoyer votre commande à votre partenaire dédié ou au constructeur du véhicule.



	oldal		oldal		oldal
Funkcióáttekintés egyik oldalra eltolható	2	Tető kinyitása	3	Karbantartás és ápolás	22
Funkcióáttekintés mindkét oldalra eltolható	9	Tető becsukása	6		
		A tető mindkét irányban eltolható	10		
		Oldal megnyitása	17		
		Oldal becsukása	19		
		A jármű vezetése	21		



További információ  
honlapunkon található  
([www.EdschaTS.com](http://www.EdschaTS.com))



Tartalom



Magyarázatok



Rendeltetés  
sze-rinti használat



Típus  
azonosító



Funkcióáttekintés



Kezelés



Karbantartás  
és ápolás



Tető  
kinyitása



Tető  
becsuk ása



Mindkét  
irányban  
eltolható



Oldal  
megnyitása



Oldal  
becsukása



A jármű  
vezetése



A járművet le kell  
állítani!



Övvel rögzíteni



Nem szabad  
megalajozni



1 x hetente



Havonta  
egyszer



Kérjük, vegye  
figyelembe!



A helyi előírásokat  
be kell tartani



Hallhatóan  
bekattan



WD 40 vagy szilikonspray használatakor a  
ponyva szennyeződhet.



Vizuális  
ellenőrzés



Reteszelni kell



Portálállvány zár  
(opcionális)



csuklók utánállítása,  
ha az ívvasak súrlód-  
nak a síneken



helyzet

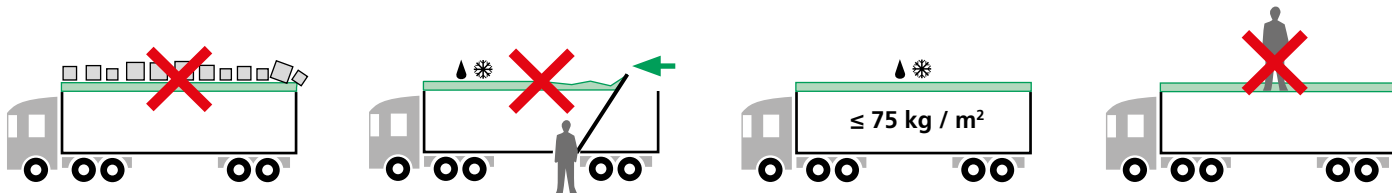

Az Edscha Trailer Systems eltolható takaróponyvái és azok kezelési részegységei kizárólag előírás szerinti használatra készültek teherautókra jellemző szállítmányozási tevékenységekhez. Az ezen túlmenő használatuk nem előírás szerintinek számít. Az ebből eredő károkkért a European Trailer Systems GmbH semminemű felelősséget sem vállal, a felelősséget a használó viseli. Az előírás szerinti használathoz tartozik a gyártó által előírt kezelési-, karbantartási- és ápolási útmutató betartása is.



### A European Trailer Systems GmbH felelősségvállalása megszűnik, ha:

- az Edscha Trailer Systems eltolható takaróponyvát, valamint szerkezeti egységeit önhatalmán megváltoztatják;
- az Edscha-TS eredeti alkatrészeit egyéb alkatrészekre cserélik ki;
- az Edscha Trailer Systems eltolható takaróponyváját, valamint kezelési egységeit nem az érvényes Edscha Trailer Systems előírásoknak megfelelően kezelik és tartják karban;



A ponyvát a szállítás megkezdése előtt mindig felül kell vizsgálni látható sérülésekre és kopásokra.

Hibás és elhasználódott részeket azonnal ki kell cserélni eredeti Edscha Trailer Systems alkatrészekre.



Az egyes országok előírásait és rendelkezéseit mindig be kell tartani.

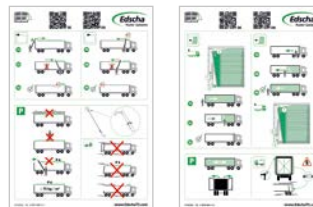

**Kezelési matrica** (ragassza fel a tgc.-ra)

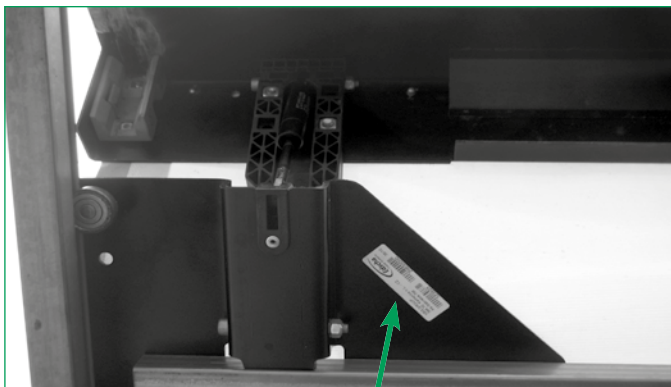

European Trailer Systems GmbH



113106

Ponyvaszám



2342014

Burkolat típus

XX/14

Gyártási hét

További információ honlapunkon található  
([www.EdschaTS.com](http://www.EdschaTS.com))

A műszaki változtatások  
joga fenntartva.



Szerelési útmutató



Javítási útmutató



Mindegyik eltolható takaróponyvát gyárilag egy „sorozatszám“ táblával látták el. Ez a jelölés a végkocsin (lásd ábra) található. Megrendelésével kérjük, forduljon illetékes partneréhez, ill. járműgyártójához.



	Pagina		Pagina		Pagina
Panoramica delle funzioni scorrevole su un lato	2	Apertura del tetto	3	Manutenzione e riparazione	22
Panoramica delle funzioni scorrevole su entrambi i lati	9	Chiusura laterale	6		
		Tetto scorrevole su entrambi i lati	10		
		Apertura laterale	17		
		Chiusura laterale	19		
		Marcia	21		



Ulteriori informazioni sono disponibili sul sito internet **(www.EdschaTS.com)**





**Specifiche del contenuto**



**Spiegazioni**



**Uso appropriato**



**Identificazione del modello**



**Panoramica delle funzioni**



**Funzionamento**



**Manutenzione e riparazione**



**Apertura del tetto**



**Chiusura del tetto**



**Possibilità di scorrimento su entrambi i lati**



**Apertura laterale**



**Chiusura laterale**



**Marcia**



**Veicolo obbligatoriamente fermo**



**Fissaggio con cinghie**



**Non ingrassare!**



**1 volta alla settimana**



**Una volta al mese**



**Attenzione!**



**Rispettare le disposizioni locali!**



**Scatto in posizione udibile**



**Spray silicónico o WD40  
Pericolo di contaminazione del telone in caso d'impiego!**



**Ispezione visiva**



**Bloccaggio necessario**



**Blocco trave cavalletto (opzionale)**



**Eeguire le regolazioni secondarie delle articolazioni se le centine effettuano il trascinamento lungo le guide.**



**Posizione**

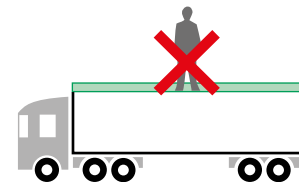
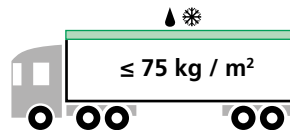
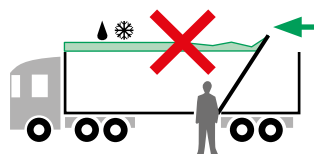
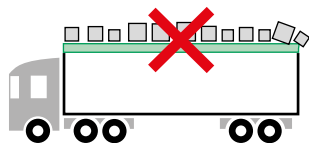

I teloni scorrevoli Edscha Trailer Systems e le rispettive istruzioni per l'uso sono realizzati in modo esclusivo per l'applicazione a norma in caso di applicazioni di trasporto specifiche per camion. Ogni impiego diverso da quanto previsto è da considerarsi inappropriato. Il produttore European Trailer Systems GmbH declina ogni danno derivante da queste condizioni e l'utente si assume tutte le eventuali responsabilità in via esclusiva. Anche l'adempimento delle disposizioni previste dal produttore in materia di funzionamento, manutenzione e riparazione rientra nell'ambito del corretto impiego.



**European Trailer Systems GmbH è sollevata da tutte le eventuali responsabilità se:**

- Si apportano modifiche in modo autonomo al telone scorrevole Edscha Trailer Systems e ai rispettivi moduli.
- Si sostituiscono i pezzi originali Edscha-TS con altri moduli.
- Non si gestiscono e sottopongono a manutenzione il telone scorrevole Edscha Trailer Systems e i rispettivi moduli di azionamento in base alle direttive Edscha Trailer Systems in vigore.



Prima di dare inizio ad ogni marcia, è necessario verificare la presenza di danni e segni d'usura riconoscibili nel telone.

È necessario sostituire immediatamente i componenti difettosi ed usurati con pezzi originali Edscha Trailer Systems.



**È tassativamente obbligatorio rispettare le regolamentazioni e le disposizioni nazionali.**

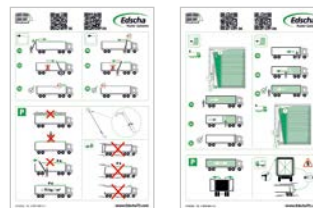

**Etichetta del funzionamento** (applicare al camion)

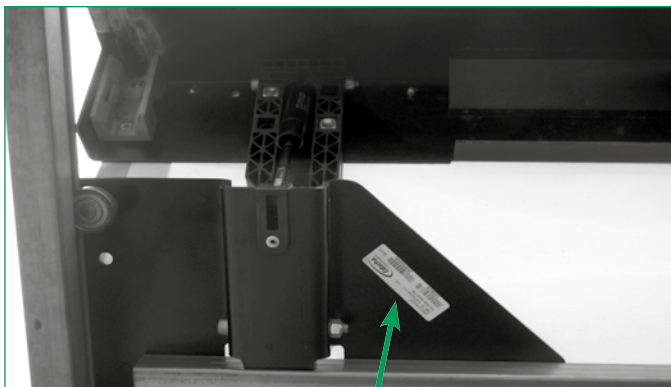

Ulteriori informazioni sono disponibili sul sito internet  
([www.EdschaTS.com](http://www.EdschaTS.com))

L'azienda produttrice si riserva il diritto di  
apportare eventuali modifiche tecniche.

European Trailer Systems GmbH

**Edscha**  
Trailer Systems



113106

Codice del telone



234/2014

**Modello del telone**

XX/14

Settimana di  
produzione



Istruzioni per il  
montaggio



Istruzioni per la  
riparazione



Tutti i teloni scorrevoli sono contrassegnati di fabbrica da una targhetta del „numero di serie“. La marcatura è fissata al carrello finale (vedere l'illustrazione). L'ordine effettuato fa riferimento al partner o al produttore di veicoli competente.



	ページ		ページ		ページ
機能概要 片側調整式	2	ルーフを開く	3	保守とお手入れ	22
機能概要 両側調整式	9	ルーフを閉じる	6		
		上部は両側スライド可能	10		
		サイドを開く	17		
		サイドを閉じる	19		
		運転	21		



詳細情報は、弊社のインターネット ページ ([www.EdschaTS.com](http://www.EdschaTS.com)) をご覧ください。



内容



説明



意図した用途



種類の識別



機能概要



操作



保守とお手入れ



ルーフを開く



ルーフを閉じる



両側スライド可能



サイドを開く



サイドを閉じる



運転



停車すること！



ベルトで固定



注油しないこと



週1回



月に一回



必ず守ること！



各地域の法規に順守



はめ込む音がする



シリコンまたはグラファイトスプレー  
使用時：ターボリンが汚れるおそれ



目視確認



ロックが必要です



ガントリー・ビーム・ロック  
(オプション)



フープがレールに擦れる  
場合はジョイントを  
調整してください



位置

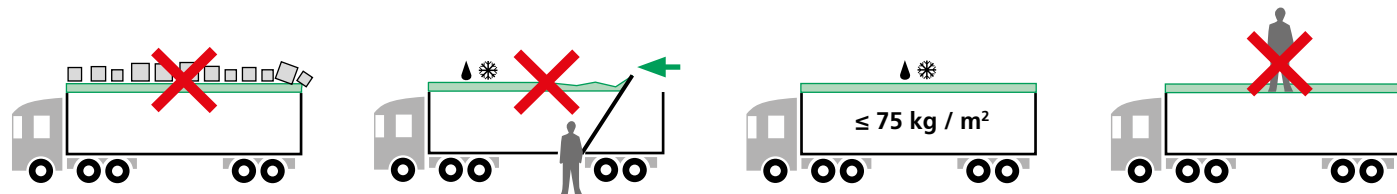

Edscha Trailer Systems スライディング・ルーフおよびその操作部品は、トラック専用の輸送用途において、規定に基づいた使用のためにのみ製造されています。それ以外の使用は誤用であると見なされます。製造元である European Trailer Systems GmbH は、その結果生じた損害に対するいかなる責任も負いません。そのリスクを負うのは使用者のみです。操作、保守およびお手入れについての製造元の指示に順守することも、意図した用途に含まれます。



以下の場合、製造元である European Trailer Systems GmbH はいかなる責任も負いません：

- Edscha Trailer Systems スライディング・ルーフおよびその構成部品を自己判断により変更すること、
- Edscha Trailer Systems 純正製品を他の部品と交換した場合
- Edscha Trailer Systems スライディング・ルーフおよびその操作部品の操作および保守にあたり、Edscha Trailer Systems の所定のガイドラインに従わなかった場合



走行を開始する前に、その都度ルーフの外観に損傷や摩耗が無い点検します。

部品に不具合および摩耗がある場合は、直ちに Edscha Trailer Systems 社製の純正部品と交換してください。



各国の規定や法規に必ず順守してください。

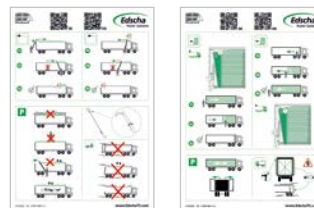

取扱方法シール (トラックに適用)

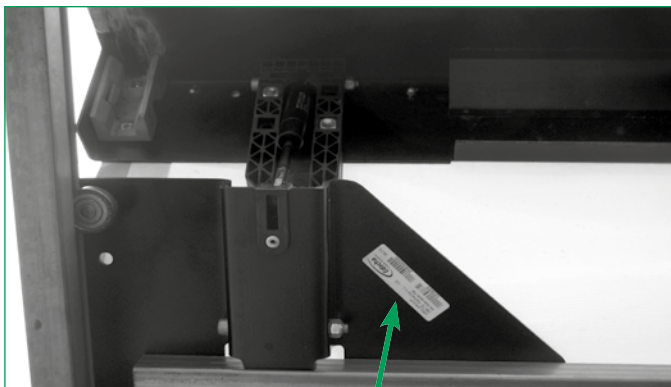

European Trailer Systems GmbH



113106

シリアルナンバー



234|2014

ルーフの種類

XX/14

製造週

詳細情報は、弊社のインターネット ページ  
([www.EdschaTS.com](http://www.EdschaTS.com)) をご覧ください。

技術的変更が行われること  
があります。



取り付けマニュアル



修理マニュアル



スライディング・ルーフには、製造時にそれぞれ「シリアル番号」のプレートが付けられています。このラベルはエンドキャリッジ (図を参照) に記載されています。ご注文は各地域の担当パートナーまたは車両メーカーで承ります。

**Puslapis**

Funkcijų apžvalga 2  
perstumiama į vieną pusę

Funkcijų apžvalga 9  
perstumiama į abi puses

**Puslapis**

Atidaryti stogą 3

Uždaryti stogą 6

Stogas užstumiamas 10  
iš abiejų pusių

Atidaryti šoną 17

Uždaryti šoną 19

Važiavimas 21

**Puslapis**

Priežiūra ir techninė 22  
priežiūra



Daugiau informacijos  
rasite mūsų interneto  
svetainėje  
**(www.EdschaTS.com)**





Turinys



Paiškinimai



Naudojimas pagal paskirtį



Tipo identifikavimas



Funkcijų apžvalga



Naudojimas



Priežiūra ir techninė priežiūra



Atidaryti stogą



Uždaryti stogą



Užstumiamas iš abiejų pusių



Atidaryti šoną



Uždaryti šoną



Važiavimas



Transporto priemonė turi stovėti!



Užfiksuoti diržų



Netepti alyva



1 x per savaitę



Kartą per mėnesį



Būtina laikytis!



Laikytis vietinių taisyklių



Užsifiksuoja spragtelėdamas



Silikono purškiklis arba WD40  
Naudojant: gali būti užterštas brezentas



Vizualinė patikra



Būtina užrakinti



Rėmo sijos užraktas (įsigyjamas atskirai)



Jei lankai praslysta ant bėgelio, pakoreguokite lanką



Padėtis

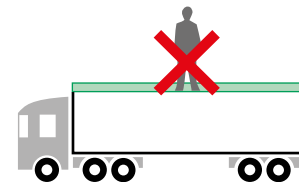
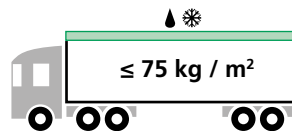
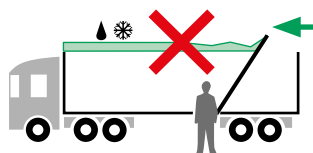
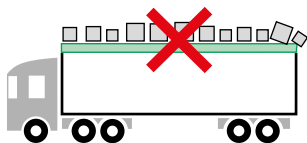

„Edscha Trailer Systems“ stumdami tentai ir jų valdymo mazgai skirti naudoti tik krovininėse transporto priemonėse pagal numatytąją paskirtį. Bet koks kitoks naudojimas laikomas naudojimu ne pagal paskirtį. Dėl nuostolių, atsiradusių naudojant gaminį ne pagal paskirtį, gamintojas European Trailer Systems GmbH neprisiima jokios atsakomybės, visa rizika tenka naudotojui. Naudojimu pagal paskirtį taip pat laikomas visų gamintojo pateikiamų naudojimo, priežiūros ir techninės priežiūros nurodymų laikymasis.



**Gamintojas, European Trailer Systems GmbH, neprisiims jokios atsakomybės, jei:**

- savo nuožūra buvo keičiamas „Edscha Trailer Systems“ stumdomas tentas ar jo mazgai;
- „Edscha-TS“ originalios dalys buvo pakeistomis kitomis;
- „Edscha Trailer Systems“ stumdomas tentas ir jo valdymo mazgai naudojami ir prižiūrimi ne pagal galiojančias „Edscha Trailer Systems“ instrukcijas.



Prieš kiekvieną važiavimą reikia apžiūrėti tentą, ar nėra matomų pažeidimų ir nusidėvėjimo žymių.

Sugedusias ar nusidėvėjusias dalis reikia nedelsiant pakeisti originaliomis „Edscha Trailer Systems“ dalimis.



**Būtina laikytis atitinkamoje šalyje galiojančių taisyklių ir potvarkių**

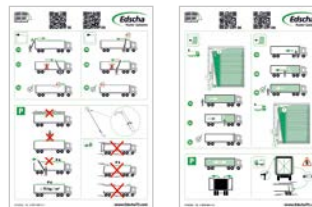

**Lipdukas Darbas (uždėti ant sunkvežimio)**

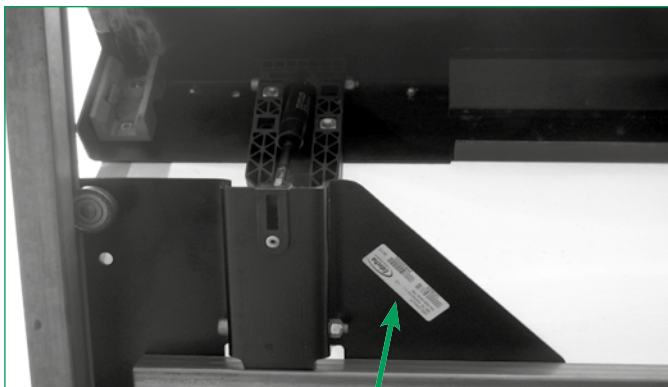

European Trailer Systems GmbH

**Edscha**  
Trailer Systems



113106



234|2014

XX/14

Tento serijos numeris

**Tento tipas**

Pagaminimo savaitė

Daugiau informacijos rasite mūsų interneto svetainėje  
([www.EdschaTS.com](http://www.EdschaTS.com))

Pasiliekiama teisė daryti  
techninius pakeitimus.



Montavimo instrukcija



Remonto instrukcija



Kiekvienas stumdomas tentas gamykloje pažymimas ženklu „Serijos numeris“. Šis ženklas yra pritvirtintas prie važiuoklės (žr. paveikslėlį). Užsakymą pateikite atsakingam gamintojo partneriui ar transporto priemonės gamintojui.



Funkciju pārskats  
pārbidāms uz vienu pusi

Lpp.

2



Atvērt jumta pārsegu 3

Lpp.

3

Tehniskā apkope un  
kopšana

Lpp.

22

Funkciju pārskats  
pārbidāms uz abām pusēm

9



Aizvērt jumta pārsegu 6



Jumtu iespējams  
pārbidīt uz abām pusēm 10



Atvērt sānu sienu 17



Aizvērt sānu sienu 19



Braukšana 21



Sikāku informāciju jūs  
atradīsiet mūsu tīmekļa  
vietnē  
**(www.EdschaTS.com)**



Satura rādītājs



Paskaidrojumi



Paredzētā lietošana



Tipa identifikācija



Funkciju pārskats



Ekspluatācija



Tehniskā apkope un kopšana



Atvērt jumta pārsegu



Aizvērt jumta pārsegu



Pārbidāms uz abām pusēm



Atvērt sānu sienu



Aizvērt sānu sienu



Braukšana



Transportlīdzeklim jāstāv!



Nostiprināt ar siksnu



Neeļļot



1 x nedēļā



Reizi mēnesī



Obligāti jāievēro!



Jāievēro vietējie noteikumi



Dzirdama nofiksēšanās



Silikona aerosol vai WD40. Izmantojot: brezenta piesārņošanas risks



Vizuāla pārbaude



Nepieciešama nobloķēšana



Traversa šķērša slēdzis (izvēles)



Noregulējiet savienojumus, ja notiek karkasa berze pret slīdēm



Pozīcija

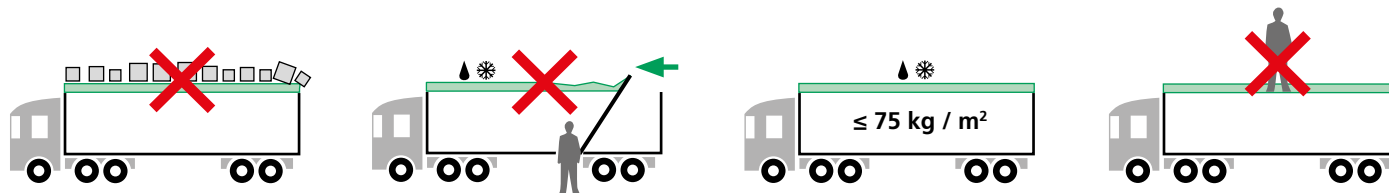

Edscha Trailer Systems bīdāmie jumti un to apkalpošanas elementi izgatavoti tikai noteikumiem atbilstošajam kravas automašīnu specifiskā transporta lietojumam. Jebkura cita veida izmantošana nav atļauta. Par šādi izrietošiem bojājumiem ražotājs European Trailer Systems GmbH neatbild, visu risku uzņemas lietotājs. Noteikumiem atbilstoša lietošana ietver arī ražotāja noteikto ekspluatācijas, tehniskās apkopes un kopšanas instrukciju ievērošanu.



**Ražotājs European Trailer Systems GmbH tiek atbrīvots no atbildības, ja:**

- Edscha Trailer Systems bīdāmo jumtu un tā elementus pašrocīgi mainīt;
- Edscha-TS oriģinālās detaļas tiek apmainītas pret citām detaļām;
- Edscha Trailer Systems bīdāmo jumtu un tā apkalpošanas elementus apkalpot un apkopt saskaņā ar spēkā esošajām Edscha Trailer Systems vadlīnijām.



Pirms katra brauciena uzsākšanas pārbaudīt, vai jumts nav manāmi bojāts un nodilis.

Bojātās un nodilušās detaļas nekavējoties jānomaina pret Edscha Trailer Systems oriģinālajām detaļām.



**Obligāti jāievēro attiecīgās valsts noteikumi un nosacījumi!**

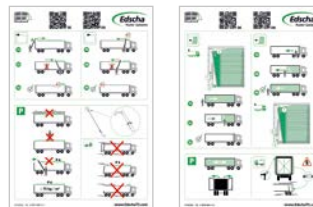

**Ekspluatācijas uzlīme (uzlīmēt automašīnai)**

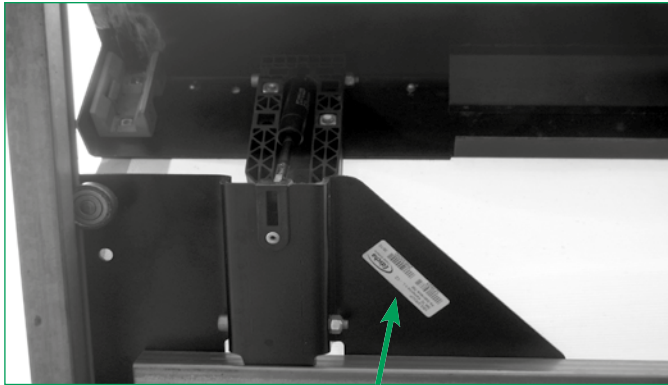

Sīkāku informāciju jūs atradīsiet mūsu tīmekļa vietnē  
([www.EdschaTS.com](http://www.EdschaTS.com))

Ražotājs patur tiesības veikt tehnisko  
parametru izmaiņas.



Montāžas instrukcija



Remonta instrukcija



European Trailer Systems GmbH

XX/14

Jumta pārsega numurs

**Jumta pārsega tips**

Ražošanas nedēļa

Katrs bidāmais jumts rūpniecā tiek marķēts ar plāksni „Sērijas numurs“. Šis marķējums ir piestiprināts pie pēdējā slidņa (skatīt attēlu). Lūdzu, adresējiet pasūtījumu savam vietējam partnerim vai transportlīdzekļa ražotājam.



	Pagina		Pagina		Pagina
Overzicht van functies verschuifbaar naar één kant	2	Dak openen	3	Onderhoud en instandhouding	22
Overzicht van functies verschuifbaar naar twee kanten	9	Dak sluiten	6		
		Dak beide kanten verschuifbaar	10		
		Zijkant openen	17		
		Zijkant sluiten	19		
		Rijden	21		



Meer informatie vindt u op  
onze internetsite  
**(www.EdschaTS.com)**





Inhouds-opgave



Verklaringen



Gebruik volgens  
de voorschriften



Typeaanduiding



Overzicht van  
functies



Bediening



Onderhoud en  
instandhouding



Dak openen



Dak sluiten



Beide kanten  
verschuifbaar



Zijkant openen



Zijkant sluiten



Rijden



Voertuig moet  
stilstaan!



Met riem  
vastzetten



Niet smeren



1 x per week



1x per maand



Beslist in acht  
nemen!



Plaatselijke voor-  
schriften in acht  
nemen



Vergrendeling  
hoorbaar



Siliconenspray of WD40  
Bij gebruik: risico van vuil  
worden van het dekzeil



Visuele controle



Vergrendelen  
noodzakelijk



Portaalbalkverg-  
rendeling  
(optioneel)



stel de scharnieren  
af als de dakbogen  
tegen de rails aan-  
lopen



positie

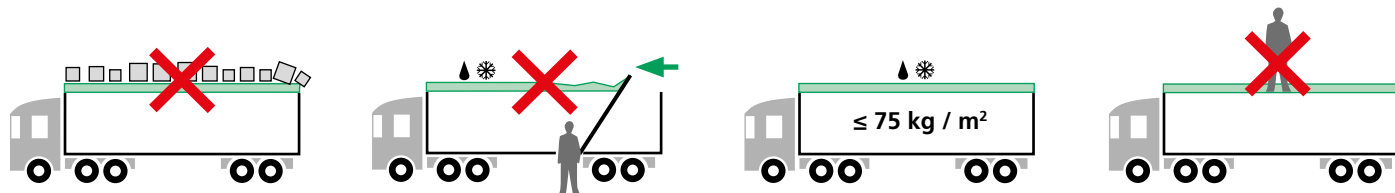

De schuifhuiden van Edscha Trailer Systems en de bedieningselementen ervan, zijn uitsluitend gemaakt voor gebruik conform de voorschriften bij vrachtwagenspecifieke transportwerkzaamheden. Ieder verdergaand gebruik, geldt als verkeerd gebruik dat buiten de voorschriften valt. Voor schade die hieruit voortvloeit aanvaardt de fabrikant European Trailer Systems GmbH geen enkele aansprakelijkheid; de risico's zijn in dit geval geheel voor rekening van de gebruiker. Tot het gebruik volgens de voorschriften behoort ook het in acht nemen van de door de fabrikant voorgeschreven bedienings-, onderhouds- en instandhoudingsaanwijzingen.



**Iedere aansprakelijkheid van de fabrikant European Trailer Systems GmbH vervalt, wanneer:**

- de schuifhuid van Edscha Trailer Systems en/of de onderdelen ervan eigenmachtig gemodificeerd worden;
- de originele onderdelen van Edscha-TS door andere onderdelen vervangen worden,
- de schuifhuid van Edscha Trailer Systems en/of de bedieningselementen ervan niet conform de geldende richtlijnen van Edscha Trailer Systems bediend en onderhouden worden.



Vóór het begin van iedere rit moet de huid op herkenbare beschadigingen en slijtage worden gecontroleerd.

Defecte en versleten onderdelen moeten onmiddellijk worden vervangen door originele onderdelen van Edscha Trailer Systems.



**Bepalingen en voorschriften van het betreffende land moeten beslist in acht worden genomen**

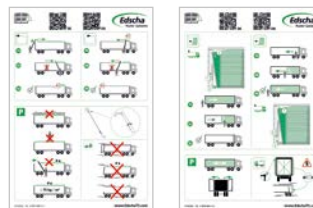

**Sticker bediening** (aanbrengen op de vrachtwagen)

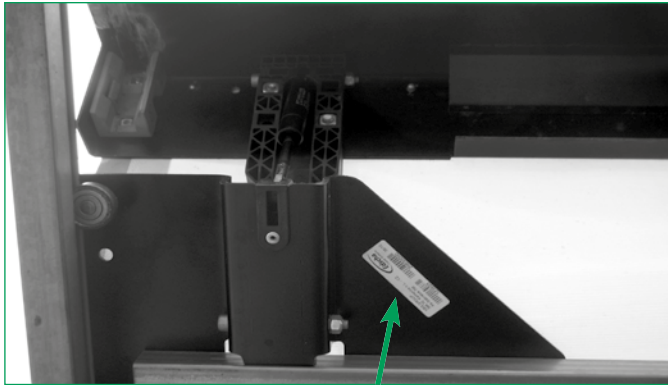

Meer informatie vindt u op onze internetsite  
**(www.EdschaTS.com)**

Alle technische wijzigingen  
 voorbehouden.



Montagehandleiding



Reparatiehandleiding



European Trailer Systems GmbH

113106

2342014

XX/14

Huifnummer

**Huiftype**

Productieweek

Iedere schuifhuif is in de fabriek gekenmerkt middels een bordje ,serienummer'. Dit bordje is op de eindtrolley (zie afbeelding) bevestigd. Stuur uw bestelling a.u.b. naar de voor u verantwoordelijke partner of naar de fabrikant van het voertuig.



strona

strona

strona

Przegląd funkcji jednostronnie przesuwny

2



Otworzyć dach

3

Konserwacja i utrzymanie w dobrym stanie

9

Przegląd funkcji obustronnie przesuwny



Zamknąć dach

6



Dach obustronnie przesuwny

10



Otworzyć bok

17



Zamknąć bok

19



Jazda

21



Dalsze informacje znajdują Państwo na naszej stronie internetowej ([www.EdschaTS.com](http://www.EdschaTS.com))



Treść



Objaśnienia



Użytkowanie zgodnie z przeznaczeniem



Identyfikacja typu



Przegląd funkcji



Obsługa



Konserwacja i utrzymanie w dobrym stanie



Otworzyć dach



Zamknąć dach



Obustronnie przesunąć



Otworzyć bok



Zamknąć bok



Jazda



Pojazd musi stać!



Zabezpieczyć pasem



Nie smarować olejem



1 x w tygodniu



Raz w miesiącu



Koniecznie pamiętać!



Przestrzegać przepisów lokalnych



Słyszalne zatrzaśnięcie



Silikon aerozolu lub WD40 Podczas stosowania: niebezpieczeństwo zabrudzenia plandeki



kontrola wizualna



Blokada wymagana



Blokada belki przesuwnic (opcjonalna)



Wyregulować przeguby, jeśli pałki trą o szyny



Pozycja

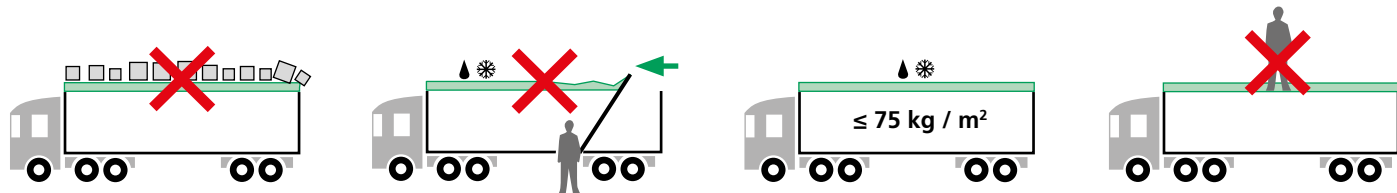

Dachy przesuwne Edscha Trailer Systems i części służące do ich obsługi nadają się wyłącznie do zgodnych z przepisami zastosowań w transporcie ciężarowym. Każde zastosowanie wychodzące poza ten zakres uznawane jest za niezgodne z przeznaczeniem. Za wynikające z tego szkody producent European Trailer Systems GmbH nie ponosi odpowiedzialności, ryzyko ponosi wyłącznie użytkownik. Zastosowanie zgodne z przeznaczeniem obejmuje także przestrzeganie wskazówek producenta dotyczących obsługi, konserwacji i utrzymania w dobrym stanie.



### Odpowiedzialność producenta European Trailer Systems GmbH wygasa, gdy:

- Dach przesuwny Edscha Trailer Systems oraz jego części zostaną samowolnie zmodyfikowane;
- oryginalne części Edscha-TS zostaną zastąpione innymi częściami;
- Dach przesuwny Edscha Trailer Systems oraz części służące do jego obsługi nie będą użytkowane i konserwowane zgodnie z obowiązującymi wytycznymi Edscha Trailer Systems.



Przed rozpoczęciem jazdy dach należy sprawdzić pod kątem widocznych uszkodzeń i zużycia.

Uszkodzone i zużyte części należy niezwłocznie wymieniać na oryginalne części Edscha Trailer Systems.



Należy obowiązkowo przestrzegać wytycznych i przepisów obowiązujących w kraju użytkowania

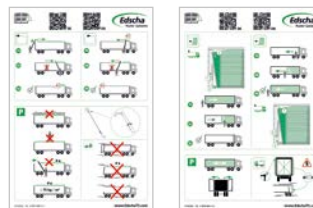

**Naklejka z obsługą (umieścić na ciężarówce)**

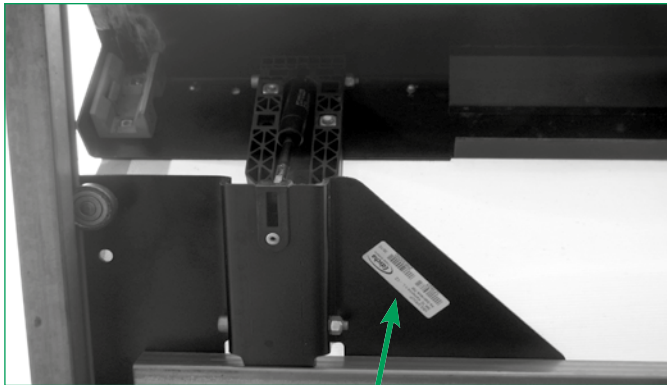

European Trailer Systems GmbH

**Edscha**  
Trailer Systems



113106

numer dachu



234|2014

**typ dachu** tydzień produkcji

XX/14

Dalsze informacje znajdują Państwo na naszej stronie internetowej  
([www.EdschaTS.com](http://www.EdschaTS.com))

Wszelkie zmiany techniczne  
zastrzeżone.



Instrukcja montażu



Instrukcja naprawy



Każdy dach przesuwany jest fabrycznie oznaczony tabliczką „numer seryjny”. To oznaczenie znajduje się na tylnej belce (patrz zdjęcie). Zamówienie należy kierować do partnera handlowego lub producenta pojazdu.



Visão geral da função  
deslizamento unilateral

Página

2



Abrir tecto

3

Manutenção e  
conservação

Página

22

Visão geral da função  
pode ser movido para  
ambos os lados

9



Fechar tecto

6



Cobertura deslocável  
de ambos os lados

10



Abrir lateral

17



Fechar lateral

19



Iniciar a marcha

21



Poderá encontrar mais  
informações na nossa pá-  
gina de Internet  
**(www.EdschaTS.com)**





Índice



Explicações



Utilização apropriada



Identificação do tipo



Visão geral da função



Utilização



Manutenção e conservação



Abrir tecto



Fechar tecto



Movimentável para ambos os lados



Abrir lateral



Fechar lateral



Iniciar a marcha



O veículo tem de estar parado!



Proteger com cinto



Não olear



1 x por semana



Uma vez por mês



Observar imprete-  
rivelmente!



Observar as nor-  
mas locais



Engate audível



Vaporizador de silicone ou WD40  
Em caso de utilização:  
Perigo de sujar o toldo



controlo visual



Bloqueio necessário



Fecho de viga de pórtico (opcional)



ajustar as juntas se os arcos se arrastarem sobre os carris



posição

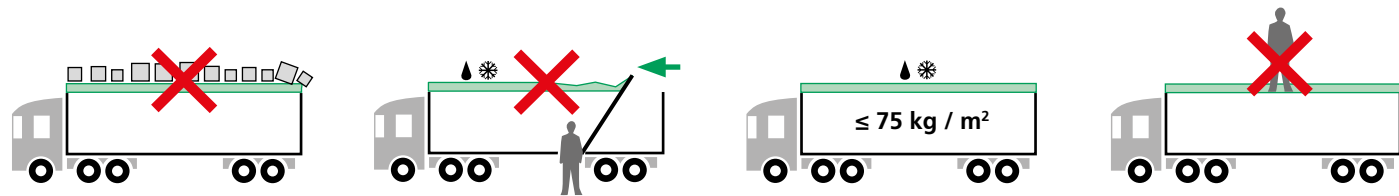

As coberturas de correr da Edscha Trailer Systems e os seus componentes de serviço são fabricados exclusivamente para a utilização correta em transporte específico em camião. Qualquer outra utilização não é apropriada. O fabricante European Trailer Systems GmbH declina qualquer responsabilidade por danos daí resultantes, sendo apenas o utilizador a suportar os riscos. Também faz parte da utilização correcta a observação das instruções de utilização, manutenção e conservação prescritas pelo fabricante.



**É anulada qualquer responsabilidade do fabricante European Trailer Systems GmbH se:**

- A cobertura de correr da Edscha Trailer Systems e os seus componentes forem alterados arbitrariamente;
- as peças originais Edscha TS forem substituídas por outros componentes
- Não operar nem efetuar a manutenção da cobertura de correr da Edscha Trailer Systems e dos seus componentes de serviço de acordo com as diretrizes válidas da Edscha Trailer Systems.



Antes de cada viagem, verificar se existem danos ou desgaste óbvio na cobertura.

As peças defeituosas e gastas devem ser imediatamente substituídas por peças originais da Edscha Trailer Systems.



**Observar impreterivelmente as disposições e normas do respectivo país**

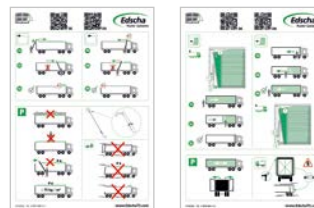

**Autocolante Operação** (a aplicar no camião)

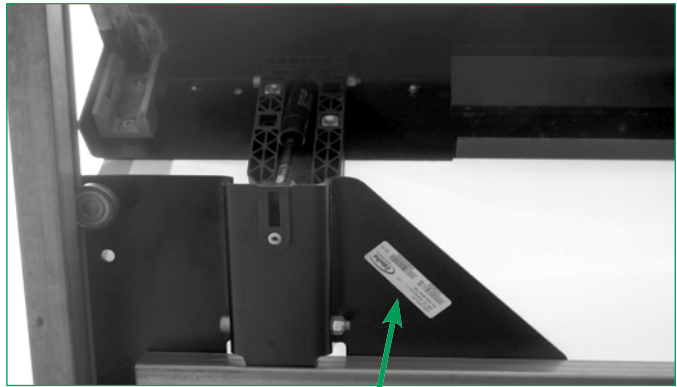

Poderá encontrar mais informações na nossa página de Internet ([www.EdschaTS.com](http://www.EdschaTS.com))  
Reservado o direito a todas as alterações técnicas.

European Trailer Systems GmbH

113106

2342014

XX/14

Número da cobertura

**Tipo de cobertura**

Semana de produção



Manual de montagem



Manual de reparação



Cada cobertura de correr é marcada pela fábrica com uma placa de „número de série“. Esta identificação está fixada no carro final (ver imagem). Queira fazer a sua encomenda junto do parceiro responsável ou fabricante de veículos.



	Pagina		Pagina		Pagina
Sumatul funcțiilor deplasabil unilateral	2	Deschidere acoperiș	3	Revizie și întreținere	22
Sumatul funcțiilor deplasabil bilateral	9	Închidere acoperiș	6		
		Acoperiș deplasabil pe ambele părți	10		
		Deschidere parte laterală	17		
		Închidere parte laterală	19		
		Deplasare	21		



Alte informații găsiți pe  
pagina noastră de in-  
ternet  
**(www.EdschaTS.com)**



Conținut



Explicații



Utilizare co-  
respunzătoare  
scopului



Identificare tip



Sumatul funcțiilor



Operare



Revizie și  
întreținere



Deschidere  
acoperiș



Închidere  
acoperiș



Deplasabil pe  
ambele părți



Deschidere parte  
laterală



Închidere parte  
laterală



Deplasare



Autovehiculul  
trebuie să  
stationeze!



Se asigură cu  
centură



Nu se lubrifiază



1 x pe săptămână



o dată pe lună



A se respecta  
obligatoriu!



A se respecta  
prevederile locale



Blocare cu clichet



Spray de silikon sau WD40  
La utilizare: pericol de murdărire a prelatei



Control vizual



Blocare necesară



Blocare macara  
portal  
(opțional)



Reglați îmbinările  
în cazul în care tra-  
versele se freacă  
pe șine



Poziție

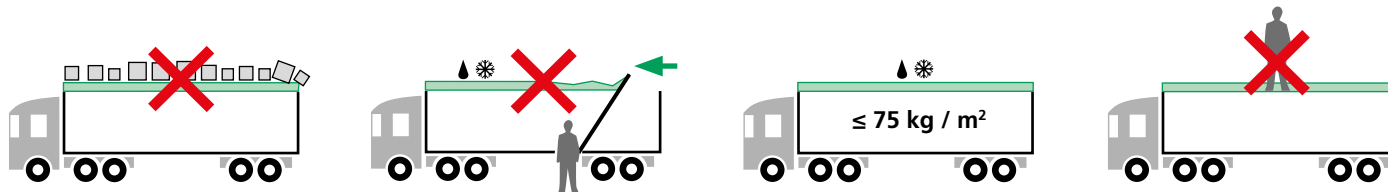

Sistemele de prelate culisante Edscha Trailer Systems și subansamblurile de operare ale acestora sunt realizate exclusiv pentru utilizarea conform destinației în cadrul transportului specific cu autocamioane. Oricare altă utilizare este considerată necorespunzătoare scopului. Pentru daunele cauzate de aceasta producătorul European Trailer Systems GmbH nu preia nicio răspundere, riscurile și le asumă doar utilizatorul. La utilizarea corespunzătoare scopului se numără de asemenea, respectarea instrucțiunilor de operare, revizie și întreținere ale producătorului.



**Orice răspundere a producătorului European Trailer Systems GmbH se anulează dacă:**

- sistemul de prelată culisantă Edscha Trailer Systems cât și subansamblurile acestuia sunt modificate în regie proprie;
- se schimbă piesele originale ale Edscha-TS cu alte subansambluri,
- sistemul de prelată culisantă Edscha Trailer Systems, cât și subansamblurile acestuia de operare nu sunt utilizate și întreținute conform liniilor de ghidare în vigoare ale Edscha Trailer Systems.



Înainte de începerea fiecărei curse trebuie să se verifice dacă există deteriorări vizibile și uzură la prelată.

Componente defecte sau uzate trebuie schimbate nemijlocit cu piese originale de schimb ale Edscha Trailer Systems.



**Prevederile și reglementările respectivei țări trebuie respectate obligatoriu**

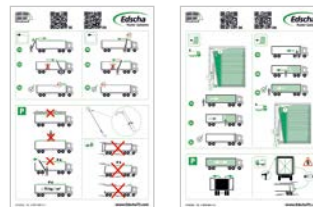

**Autocolant utilizare (de lipit pe camion)**

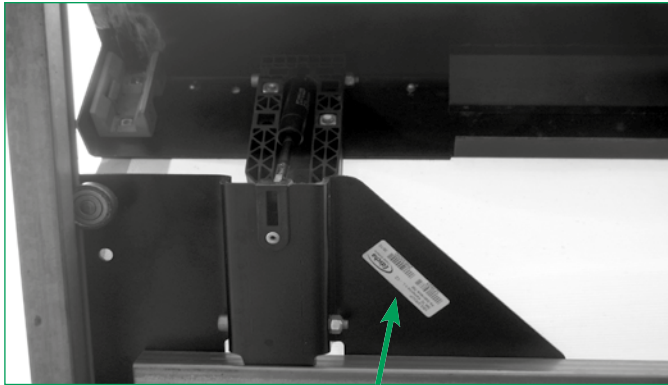

Alte informații găsiți pe pagina noastră de internet ([www.EdschaTS.com](http://www.EdschaTS.com))

Ne rezervăm dreptul la modificări tehnice.



Instrucțiuni de montaj



Instrucțiuni pentru lucrări de reparație



European Trailer Systems GmbH

113106

2342014

XX/14

Număr prelată







Tip prelată

Săptămână de producție

Fiecare prelată culisantă este marcată din fabrică cu o plăcuță cu un „număr de serie“. Această marcare este fixată pe ultima remorcă a camionului (a se vedea figura). Adresați comanda dvs. partenerului sau producătorului dvs. de autovehicule.



	Страница
Обзор функций перемещаемый в одну сторону	2
Обзор функций перемещаемый в обе стороны	9

	Страница
 Открытие крыши	3
 Закрытие крыши	6
 Крыша сдвигается в обе стороны	10
 Открытие боковой стороны	17
 Закрытие боковой стороны	19
 Движение	21

	Страница
Техническое обслуживание и уход	22



Более подробную информацию вы найдете в интернете на нашем сайте ([www.EdschaTS.com](http://www.EdschaTS.com))





Содержание



Пояснения



Применение по назначению



Идентификация типа



Обзор функций



Обслуживание



Техническое обслуживание и уход



Открытие крыши



Закрытие крыши



Сдвигается в обе стороны



Открытие борта



Закрытие борта



Движение



Автомашина должна стоять!



Зафиксировать ремнем



Не смазывать



Раз в неделю



Раз в месяц



Обязательно соблюдать!



Соблюдать местные предписания



Щелчок



Силиконовый аэрозоль или WD40. При применении: опасность загрязнения тента



Визуальный контроль



Требуется блокировка



Ригель для портальной балки (опция)



Отрегулировать шарниры, если дужки трутся о рельсы



Позиция

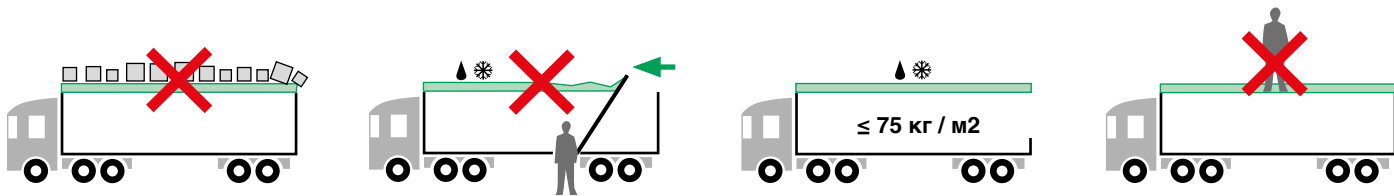

Сдвижные крыши Edscha TS и их элементы управления изготовлены исключительно для предписанного применения на грузовых автомобилях. Любое иное применение считается применением не по назначению. Производитель European Trailer Systems GmbH не несет никакой ответственности за вытекающий из этого ущерб, соответствующие риски несет исключительно пользователь. К применению по назначению относится также соблюдение инструкций производителя по эксплуатации, техническому обслуживанию и уходу.



**Производитель European Trailer Systems GmbH не несет никакой ответственности, если:**

- в конструкцию сдвижной крыши Edscha Trailer Systems и ее компонентов самовольно вносятся изменения;
- оригинальные детали Edscha TS заменяются деталями других производителей;
- сдвижная крыша Edscha Trailer Systems и ее элементы управления эксплуатируются и обслуживаются с нарушением правил Edscha Trailer Systems.



Перед каждой поездкой крышу следует проверять на предмет видимых повреждений и износа.

Неисправные или износившиеся детали немедленно заменять оригинальными деталями Edscha Trailer Systems.



**Обязательно соблюдать нормы и правила соответствующей страны!**

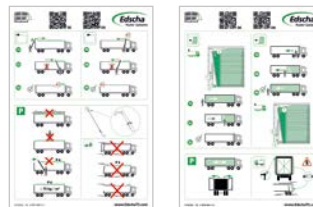

**Наклейка „Эксплуатация“** (приклеить на грузовой автомобиль)

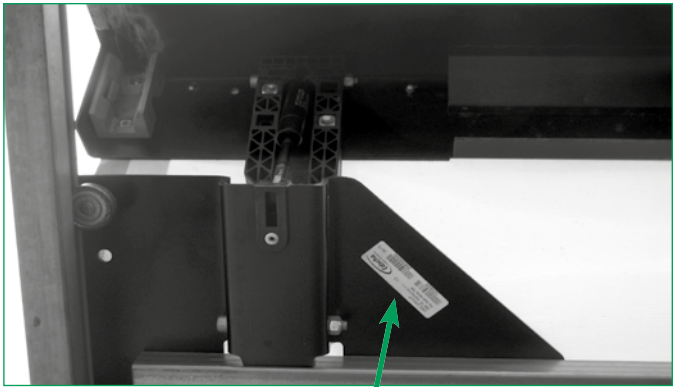

Более подробную информацию вы найдете в интернете на нашем сайте ([www.EdschaTS.com](http://www.EdschaTS.com))

Производитель оставляет за собой право на внесение технических изменений.



Инструкция по монтажу



Инструкция по ремонту



European Trailer Systems GmbH

XX/14

Номер крыши

Тип крыши

Неделя производства крыши

Каждая сдвижная крыша снабжена на заводе-изготовителе табличкой с серийным номером. Эта табличка закреплена на задней передвигной каретке (смотри рисунок). Просим направлять свой заказ соответствующему партнеру или производителю автомобилей.



	Strana		Strana		Strana
Prehľad funkcií jednostranne posuvné	2	Otvorenie strechy	3	Údržba a starostlivosť	22
Prehľad funkcií obojstranne posuvné	9	Zatvorenie strechy	6		
		Obojstranne posúvateľná strecha	10		
		Otvorenie bočnej steny	17		
		Zatvorenie bočnej steny	19		
		Jazda	21		



Ďalšie informácie nájdete na našej internetovej stránke ([www.EdschaTS.com](http://www.EdschaTS.com))



**Informácia o obsahu**



**Vysvetlivky**



**Použitie v súlade s príslušným určením**



**Identifikácia typu**



**Prehľad funkcií**



**Obsluha**



**Údržba a starostlivosť**



**Otvorenie strechy**



**Zatvorenie strechy**



**Obojstranne posúvateľná**



**Otvorenie bočnej steny**



**Zatvorenie bočnej steny**



**Jazda**



**Vozidlo musí stáť!**



**Zaistíte popruhom**



**Neolejujte!**



**1 x týždenne**



**Raz za mesiac**



**Bezpodmienečne dodržte pokyn!**



**Dodržiavajte miestne predpisy**



**Počuťné zakliknutie**



**Silikónový sprej alebo WD40**  
Pri použití: Hrozí znečistenie plachty.



**Vizuálna kontrola**



**Potrebné je uzamknutie**



**Uzamykanie portálového nosníka (voliteľné)**



**Nastavte kĺby, ak sa vzpera trú o vedenia**



**poloha**

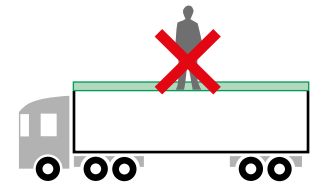
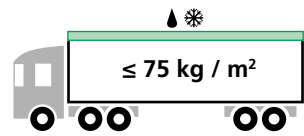
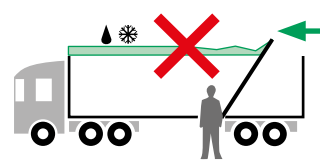
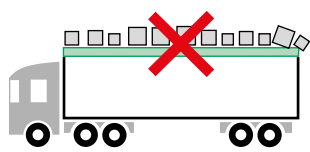

Posuvné strechy Edscha Trailer Systems a ich ovládacie prvky sú vyhotovené výlučne na použitie v súlade s predpismi pre prepravu nákladov v nákladnej doprave. Každé použitie, ktoré nie je v súlade s príslušnými predpismi a nezodpovedá typu prepravy, nie je v súlade s účelom použitia. Výrobca European Trailer Systems GmbH nenesie nijakú zodpovednosť a neručí za nijaké škody vyplývajúce z takéhoto chybného použitia, všetky riziká v takom prípade znáša používateľ. Za použitie v súlade s účelom použitia sa považuje aj dodržiavanie pokynov na obsluhu, údržbu a starostlivosť o výrobok tak, ako to predpisuje výrobca.



### Akkoľvek ručenie zo strany European Trailer Systems GmbH zaniká, ak:

- sa svojvoľne vykonajú zmeny na posuvnej streche Edscha Trailer Systems, ako aj na jej konštrukčných súčiastiach;
- sa originálne súčasti zásuvnej strechy Edscha Trailer Systems vymenia za akékoľvek iné súčasti;
- sa posuvná strecha Edscha Trailer Systems, ako aj jej ovládacie prvky neobsluhujú a neudržujú podľa platných predpisov Edscha Trailer Systems



Pred začiatkom každej jazdy je nutné skontrolovať, či na streche nie sú rozpoznateľné známky poškodenia alebo opotrebovania.

Pokazené a opotrebované súčasti je okamžite nutné vymeniť za originálne súčasti Edscha Trailer Systems.



### Bezpodmienečne dodržujte predpisy a nariadenia príslušnej krajiny.

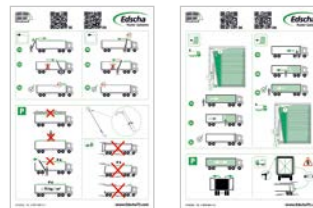

Nálepka Obsluha (nalepiť na ťahač)

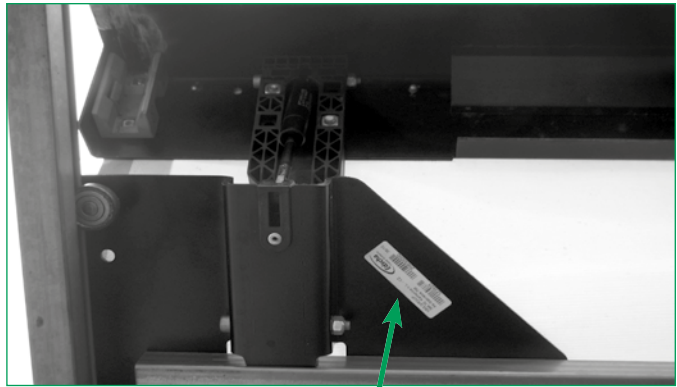

Ďalšie informácie nájdete na našej internetovej stránke  
**(www.EdschaTS.com)**

Všetky technické zmeny  
 vyhradené.



Montážny návod



Návod na opravy



European Trailer Systems GmbH

XX/14

Číslo posuvná strechy

**Typ posuvná strechy**

Týždeň výroby

Každá posuvná strecha má od výroby štítky so „sériovým číslom“. Toto označenie je upevnené na poslednom pohyblivom nosníku posuvnej strechy (viď obrázok). Objednávky zasielajte príslušnému partnerovi alebo výrobcovi vozidiel.



	Stran		Stran		Stran
Pregled delovanja možnost potiska v eno stran	2	Odpiranje strehe	3	Vzdrževanje in nega	22
		Zapiranje strehe	6		
Pregled delovanja možnost potiska v obe strani	9	Obojestransko pomična streha	10		
		Odpiranje stranice	17		
		Zapiranje stranice	19		
		Vožnja	21		



Dodatne informacije  
boste našli na naši  
internetni strani  
([www.EdschaTS.com](http://www.EdschaTS.com))





Prikaz vsebine



Razlage



Namenska  
uporaba



Identifikacija  
tipa



Pregled delovanja



Upravljanje



Vzdrževanje  
in nega



Odpiranje strehe



Zapiranje strehe



Obojestransko  
pomično



Odpiranje stranice



Zapiranje stranice



Vožnja



Vozilo mora stati!



Zavarujte s  
pasom



Ne oljite



1 x tedensko



Enkrat na mesec



Obvezno  
upoštevajte!



Upoštevajte krajevne  
predpise



Glasno se mora  
zaskočiti



Silikonsko ali WD40 pršilo  
Med uporabo: nevarnost  
onesnaženja platnene strehe



Vizualni pregled



Potrebna  
zapahnitev



Zaklep portalne  
gredi  
(opcijsko)



V primeru, da locnji  
drgnejo po tirnicah,  
prilagodite člene



Položaj

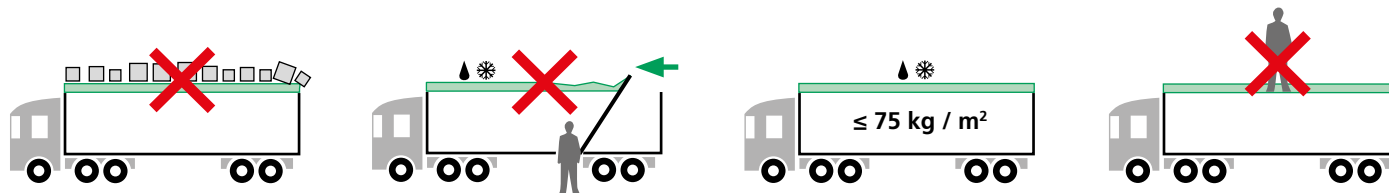

Pomične platnene strehe Edscha Trailer Systems in njihovi sestavni deli za upravljanje so izdelani izključno za predpisano uporabo pri transportu s specifičnimi transportnimi vozili. Vsaka drugačna uporaba je nenamenska. Za škodo, ki nastane zaradi tega, proizvajalec European Trailer Systems GmbH zavrača vsakršno, jamstvo, tveganje pa je izključno uporabnikovo. K namenski uporabi sodi tudi upoštevanje proizvajalčevih navodil za uporabo, vzdrževanje in nego.



### Vsako jamstvo proizvajalca European Trailer Systems GmbH preneha, če:

- so platenne strehe Edscha Trailer Systems in njihovi sestavni deli za upravljanje samovoljno spremenjeni;
- so Edscha-TS originalni nadomestni deli zamenjani z drugimi sestavnimi deli;
- se s platenimi strehami Edscha Trailer Systems in njihovimi sestavnimi deli za upravljanje, ne upravlja in se ne vzdržuje po veljavnih smernicah Edscha Trailer Systems.



Pred začetkom vsake vožnje je treba preveriti, da pomična platenena streha ni poškodovana ali obrabljena.

Uporabljene in izrabljene dele je treba takoj zamenjati z originalnimi deli Edscha Trailer Systems.



**Obvezno je treba upoštevati določila in predpise države, kjer se izdelek uporablja**

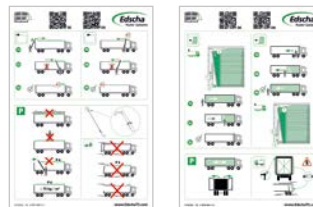

**Nalepka Uporaba** (nalepiti na tovornjak)

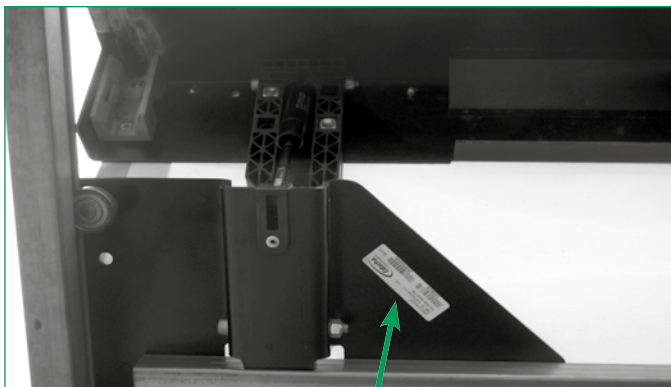

European Trailer Systems GmbH

**Edscha**  
Trailer Systems



113106

Številka platnene strehe



234/2014

**Tip platnene strehe**

Teden proizvodnje

XX/14

Dodatne informacije boste našli na naši internetni strani  
([www.EdschaTS.com](http://www.EdschaTS.com))

Pridržujemo si pravico do  
tehničnih sprememb.



Navodila za montažo



Navodila za popravilo



Vsaka pomična platnena streha je že v tovarni označena s ploščico „Serijska številka“. Ta oznaka je pritrjena na končnem tekalnem vozičku (glejte sliko). Naročila naslovite na pristojnega partnerja ali proizvajalca vozil.



	Sida		Sida		Sida
Funktionsöversikt Kan justeras (ena sidan)	2	Öppna tak	3	Underhåll och skötsel	22
Funktionsöversikt Kan justeras (båda sidor)	9	Stäng tak	6		
		Tak skjutbart åt båda sidor	10		
		Öppna sida	17		
		Stäng sida	19		
		Körning	21		



Ytterligare information  
finner ni på vår  
Internetsida  
**(www.EdschaTS.com)**



Innehållsförteckning



Förklaringar



Avsedd användning



Typskylt



Funktionsöversikt



Drift



Underhåll och skötsel



Öppna tak



Stäng tak



Skjutbart åt båda sidor



Öppna sida



Stäng sida



Körning



Fordonet måste parkeras!



Fäst säkerhetsbälte



Olja inte



1 x vecka



En gång i månaden



lakta absolut!



Följ lokala föreskrifter



Hörbart klick



Silikonspray eller WD40  
Vid användning: Risk för förorening



Visuell kontroll



Låsning krävs



Traversbalklås (tillval)



Justera länkarna om tvärgående profiler vidrör skenorna



Position

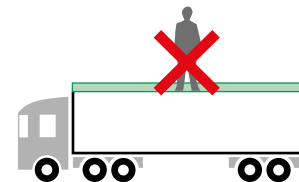
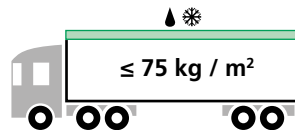
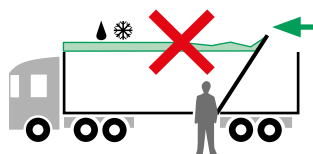
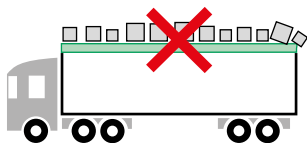

Edscha Trailer Systems skjutpresenningar och dess driftkomponenter är utformade uteslutande för den förutsedda användningen vid lastbilstransport. All annan användning anses som felaktig användning. Tillverkaren European Trailer Systems GmbH ansvarar inte för skador som orsakats av sådan användning, alla risker som har sitt ursprung häri åligger användaren. Till den avsedda användningen hör även iakttagelsen av de av tillverkaren föreskrivna bruks-, underhålls- och skötselansvisningarna.



### Allt ansvar för tillverkaren European Trailer Systems GmbH upphör om:

- Edscha Trailer Systems skjutpresenning och dess komponenter modifieras på eget bevåg;
- Edscha-TS-Originaldelar byts ut med andra komponenter
- Edscha Trailer Systems skjutpresenning och dess driftkomponenter inte används och underhålls enligt gällande Edscha Trailer Systems riktlinjer



Före varje färd ska presenningen kontrolleras för synliga skador och förlitning.

Defekta och slitna delar ska omedelbart bytas ut med originala Edscha Trailer Systems reservdelar.



Användningslandets lagar och föreskrifter ska följas utan undantag

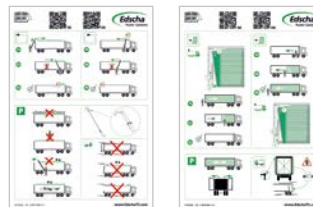

**Dekaler drift** (ska placeras på lastbilen)

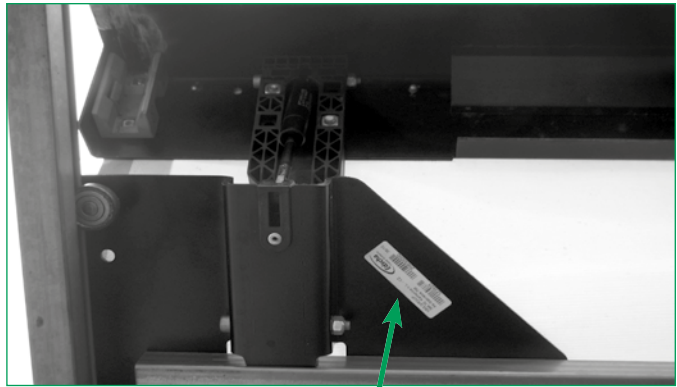

Ytterligare information finner ni på vår Internetsida ([www.EdschaTS.com](http://www.EdschaTS.com))  
 Tekniska ändringar förbehållna.

Installationsanvisning

Reparationsanvisning

**European Trailer Systems GmbH**

113106

2342014

XX/14

Presenningsnummer      **Presenningstyp**      Tillverkningsvecka

Alla skjutpresenningar har kännetecknats vid fabriken med ett „serienummer“. Denna märkning är fäst på den sista löpskenan (se bilden). För din beställning, kontakta din lokala representant eller fordonstillverkaren.



	หน้า		หน้า		หน้า
ข้อมูลทั่วไปเกี่ยวกับฟังก์ชันแบบเลื่อนได้หนึ่งด้าน	2	เปิดหลังคา	3	การบำรุงและการดูแลรักษา	22
ข้อมูลทั่วไปเกี่ยวกับฟังก์ชันแบบเลื่อนได้สองด้าน	9	ปิดหลังคา	6		
		หลังคาแบบเลื่อนได้สองด้าน	10		
		เปิดหน้า	17		
		ปิดหน้า	19		
		ขับเคลื่อน	21		



คุณสามารถดูข้อมูลเพิ่มเติมบนหน้าเว็บไซต์ของเราได้ ([www.EdschaTS.com](http://www.EdschaTS.com))





ข้อมูลสรุป



คำอธิบาย



การใช้งานตามที่กำหนดไว้



การระบุประเภท



ข้อมูลทั่วไปเกี่ยวกับฟังก์ชัน



การปฏิบัติงาน



การบำรุงและการดูแลรักษา



เปิดหลังคา



ปิดหลังคา



แบบเลื่อนได้สองด้าน



เปิดหน้า



ปิดหน้า



ขับเคลื่อน



รถต้องจอดอยู่กับที่!



ปิดด้วยสายเข็มขัด



ห้ามทำสารหลอกลืน



1 ครั้งต่อสัปดาห์



1 ครั้งต่อเดือน



ระมัดระวังเป็นพิเศษ!



ปฏิบัติตามข้อกำหนดในพื้นที่



การสวมใส่หูฟังเสียงเข้าลึก



สเปรย์ซิลิโคนหรือ WD40  
ขณะใช้งาน: ระงับอันตรายเนื่องจากผ้าใบสกปรก



การควบคุมด้วยภาพ



จำเป็นต้องล็อก



แถบพอร์ทสำหรับการล็อก (ตัวเลือก)



ปรับข้อต่อใหม่หากโครงเสริมครูดบนราง



ตำแหน่ง

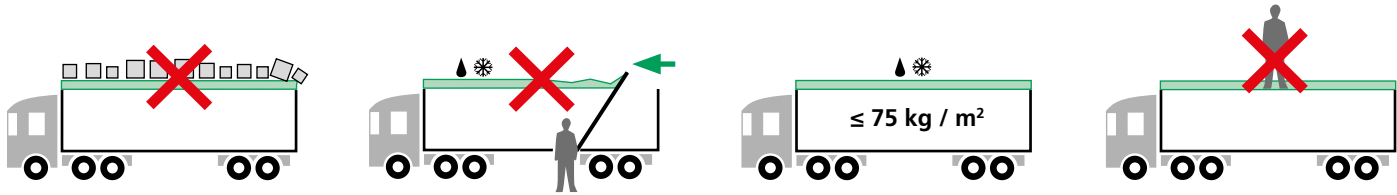

หลังคาแบบเลื่อนของ Edscha Trailer Systems และชิ้นส่วนสังงานผลิตขึ้นเพื่อการใช้งานตามข้อกำหนดสำหรับการใช้งานขนส่งเฉพาะสำหรับรถบรรทุกเท่านั้น การใช้งานนอกเหนือจากนี้จะถือว่าไม่ตรงตามข้อบังคับบริษัทผู้ผลิต European Trailer Systems GmbH จะไม่รับผิดชอบต่อความเสียหายใดๆ ที่เป็นผลมาจากการใช้งานดังกล่าว โดยผู้ใช้จะต้องรับความเสี่ยงแต่เพียงผู้เดียว การใช้งานตามที่กำหนดไว้ยังครอบคลุมถึงการปฏิบัติตามคำแนะนำเกี่ยวกับการใช้งาน การบำรุงรักษา และการดูแลรักษาที่บริษัทผู้ผลิตกำหนดไว้



**ความรับผิดชอบของบริษัทผู้ผลิต European Trailer Systems GmbH จะสิ้นสุดลงหาก:**

- หลังคาแบบเลื่อนของ Edscha Trailer Systems รวมถึงชิ้นส่วนถูกดัดแปลงโดยไม่ได้รับอนุญาต
- ชิ้นส่วนของแท่งของ Edscha TS ถูกแทนที่ด้วยชิ้นส่วนอื่น
- หลังคาแบบเลื่อนของ Edscha Trailer Systems รวมถึงชิ้นส่วนสังงานไม่ได้รับการใช้งานและบำรุงรักษาตามข้อกำหนดที่มีผลบังคับใช้ของ Edscha Trailer Systems



ก่อนการขับขี่ทุกครั้ง จำเป็นต้องตรวจสอบความชำรุดเสียหายและการสึกหรอที่สามารถตรวจพบได้บนหลังคา

ชิ้นส่วนที่ชำรุดและสึกหรอจำเป็นต้องได้รับการเปลี่ยนเป็นชิ้นส่วนของแท้ของ Edscha Trailer Systems โดยทันที



จำเป็นต้องปฏิบัติตามข้อบังคับและข้อกำหนดของแต่ละประเทศอย่างเคร่งครัด

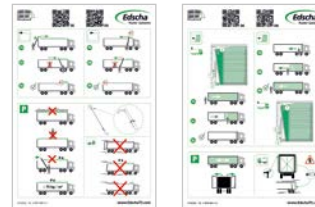

สติ๊กเกอร์สำหรับการใช้งาน (ติดที่รถบรรทุก)

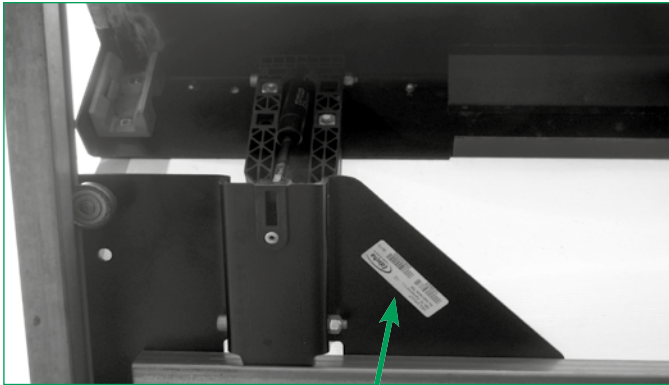

คุณสามารถดูข้อมูลเพิ่มเติมบนหน้าเว็บไซต์ของเราได้  
([www.EdschaTS.com](http://www.EdschaTS.com))

สงวนสิทธิ์การเปลี่ยนแปลงทาง  
เทคนิคทุกประการ



คู่มือการติดตั้ง



คู่มือการซ่อมแซม



European Trailer Systems GmbH

113106

2342014

XX/14

หมายเลขหลังคา

ประเภทหลังคา

อาทิตย์ที่ทำการผลิต

หลังคาแบบเลื่อนแต่ละชิ้นจะได้รับการระบุด้วยป้าย "หมายเลขลำดับการผลิต" จากโรงงาน โดยป้ายระบุนี้จะยึดอยู่บนขาลูกกึ่งท้าย (ดูที่ภาพประกอบ) โปรดส่งค่าสั่งซื้อของคุณไปยังตัวแทนจำหน่ายหรือผู้ผลิตรถยนต์ที่มีหน้าที่รับผิดชอบ



Sayfa

Sayfa

Sayfa

İşleve genel bakış  
Tek taraftan kaydırılabilir

2



Çatının açılması

3

Bakım ve temizlik

22

İşleve genel bakış  
İki taraftan kaydırılabilir

9



Çatının kapatılması

6



Çatı iki tarafa  
kaydırılabilir

10



Yan brandanın  
açılması

17



Yan brandanın  
kapatılması

19



Sürüş

21



Daha fazla bilgiyi internet  
sitemizde bulabilirsiniz  
([www.EdschaTS.com](http://www.EdschaTS.com))



İçindekiler



Açıklamalar



Amacına uygun kullanım



Tip tanımlaması



İşleve genel bakış



Kullanım



Bakım ve temizlik



Çatının açılması



Çatının kapatılması



İki tarafa kaydırılabilir



Yan brandanın açılması



Yan brandanın kapatılması



Sürüş



Araç durmalı!



Kemer ile emniyete alın



Yağlamayın



Haftada 1 kez



Ayda bir kez



Mutlaka dikkate alın!



Yerel talimatlara uyun



Duyulabilir geçme sesi



Silikon sprey veya WD40  
Kullanım esnasında:  
Brandanın kirlenme rişki



Görsel kontrol



Kilitlemek gerekir



Portal giriş kilidi  
(opsiyonel)



Yaylar raylar üzerinde sürükleniyorsa  
mafsalları yeniden ayarlayın



Pozisyon

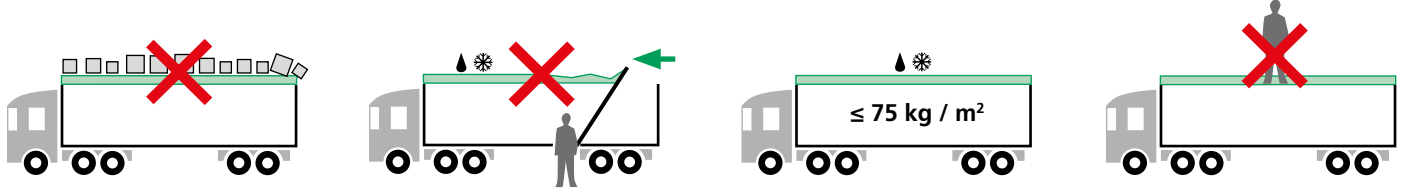

Edscha Trailer Systems kayar çatıları ve bunun kullanım bileşenleri sadece TIR'lara özgü nakliye işlemlerinde talimatlara uygun kullanım için üretilmiştir. Bunun dışındaki tüm kullanım, amacına uygun olmayan kullanım olarak değerlendirilir. European Trailer Systems GmbH bundan dolayı oluşan hasarlarda sorumluluk kabul etmemektedir; bu olay karşısında tüm risk kullanıcıya aittir. Amacına uygun kullanıma, üretici tarafından öngörülen kullanım, bakım ve temizlik talimatlarına uyulması da dahildir.



**Aşağıdaki durumlarda üretici European Trailer Systems GmbH'nin tüm sorumluluğu sona erer:**

- Edscha Trailer Systems kayar çatıları ve bunun bileşenleri keyfi olarak değiştirildiğinde;
- Edscha TS orjinal parçaları başka parçalar ile değiştirildiğinde;
- Edscha Trailer Systems kayar çatıları ve bunun kullanım bileşenleri geçerli Edscha Trailer Systems yönetmeliklerine uygun biçimde kullanılıp bakımı yapılmadığında



Çatı görülebilir hasarlar ve aşınmalar açısından seyahat öncesinde kontrol edilmelidir.

Anızalı veya aşınmış parçalar hemen orjinal Edscha Trailer Systems parçaları ile değiştirilmelidir.



**İlgili ülkedeki düzenlemelere ve talimatlara mutlaka uyulmalıdır**

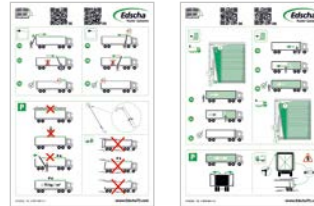

**Kullanım etiketi (araç üzerine takılır)**

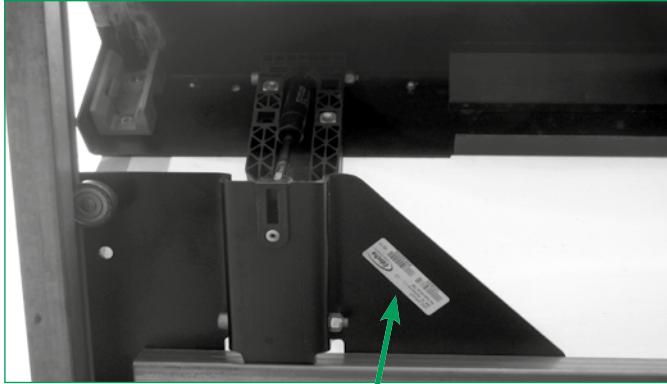

European Trailer Systems GmbH

**Edscha**  
Trailer Systems



113106

Çatı numarası



234/2014

Çatı tipi

XX/14

Üretim haftası

Ayrıntılı bilgileri İnternet sitemizde bulabilirsiniz  
([www.EdschaTS.com](http://www.EdschaTS.com))

Teknik deęişiklik hakkı saklıdır.



Montaj kılavuzu



Onarım kılavuzu



Her kayar çatı fabrika tarafından "Seri numarası" ile işaretlenmiştir. Bu etiket çatı sonuna yapıştırılmıştır (bkz. resim). Siparişinizi sizden sorumlu yetkili kişiye veya araç üreticisine iletin.



	页码		页码		页码
功能概览 单边移动	2	打开顶盖	3	保养和维护	22
功能概览 双边移动	9	关闭顶盖	6		
		顶盖可以从两边拉开	10		
		打开侧面	17		
		关闭侧面	19		
		驾驶	21		



更多信息，请访问  
我们的网站  
([www.EdschaTS.com](http://www.EdschaTS.com))





目录



说明



预期用途



类型识别



功能概览



操作



保养和维护



打开顶盖



关闭顶盖



可以从两边拉开



打开侧面



关闭侧面



驾驶



必须停车!



用系带锁住



无油



每周 1 次



一个月一次



务必注意!



遵守当地规章



喀嚓声



硅酮或石墨喷涂  
使用时：有污染防水帆布的风险



目视检查



必须锁住



门架横梁锁（可选）



如果钩架在导轨上滑动，请重新调整接头。



位置

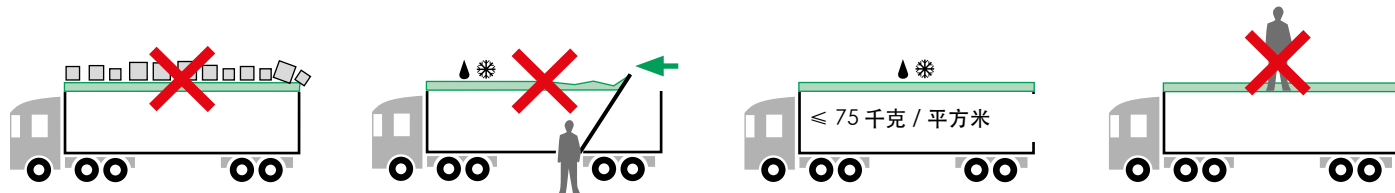

Edscha TS 拖车系统滑动车篷及其操作部件是专门为卡车从事特定运输业务而制造。超越此类应用的任何使用均视为滥用。对于造成的损害，制造商 European Trailer Systems GmbH 概不负责；用户需为此独自承担全部风险。“预期用途”还包括遵守制造商规定的操作、保养和维护说明。



如果发生下列情况，制造商 European Trailer Systems GmbH 不承担任何责任：

- 随意更改 Edscha TS 拖车系统滑动车篷及其部件；
  - 用其他部件更换 Edscha TS 的原厂配件；
  - Edscha TS 拖车系统滑动车篷及其部件未按照 Edscha TS 拖车系统的说明进行保养和维修；
- 每一次行驶前，必须检查车篷的损坏和磨损情况。



每次行驶前，应检查车篷是否有明显损坏和磨损。

损坏和磨损的部件应立即更换 Edscha TS 拖车系统的原厂配件



必须遵守相应国家的法规和规章

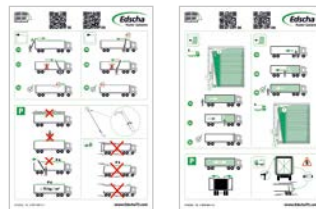

操作标签（布置在汽车上）

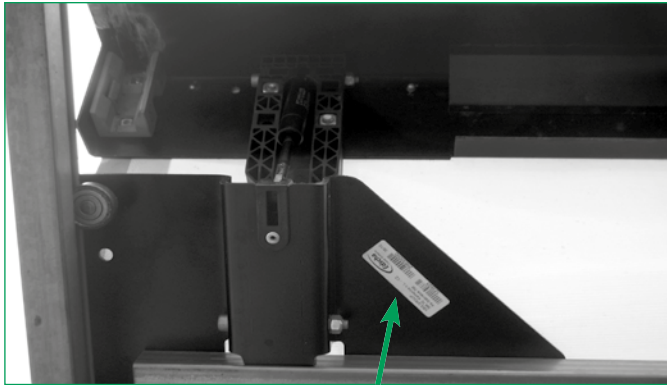

European Trailer Systems GmbH



113106

车篷编号



234|2014

车篷类型

XX/14

制造周

每个滑动车篷在出厂时都会提供“序列号”标签。此标签贴在端梁上（参见附图）。  
请将订单寄送给负责您业务的合作伙伴或汽车制造商

更多信息，请访问我们的网站  
([www.EdschaTS.com](http://www.EdschaTS.com))  
保留所有技术变更的权利。



安装说明



维修手册





11/2022 · No. 69 006 240 b

**European Trailer Systems GmbH**

Im Moerser Feld 1f, 47441 Moers, Germany

Phone: +49 (0) 2841 6070 700 · Fax: +49 (0) 2841 6070 333

Member of VBG Group



**Das Original**

[www.EdschaTS.com](http://www.EdschaTS.com)